

DATA SHEET

VXLF 2.500

ROTARY VANE VACUUM PUMPS

oil-free

air-cooled

MAKE IT BECKER.

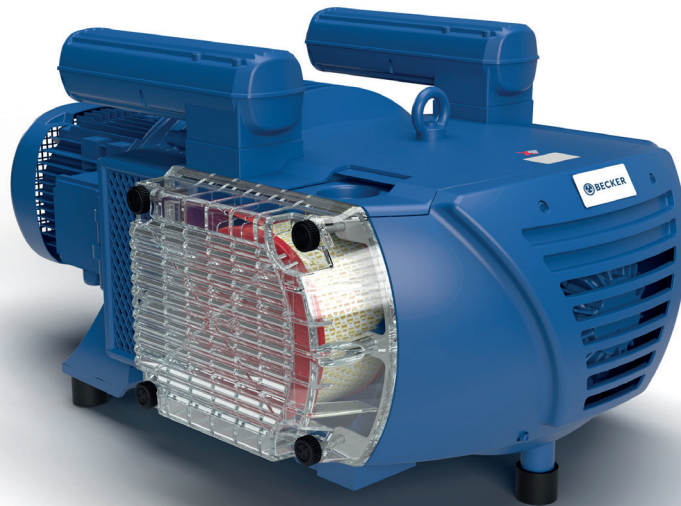
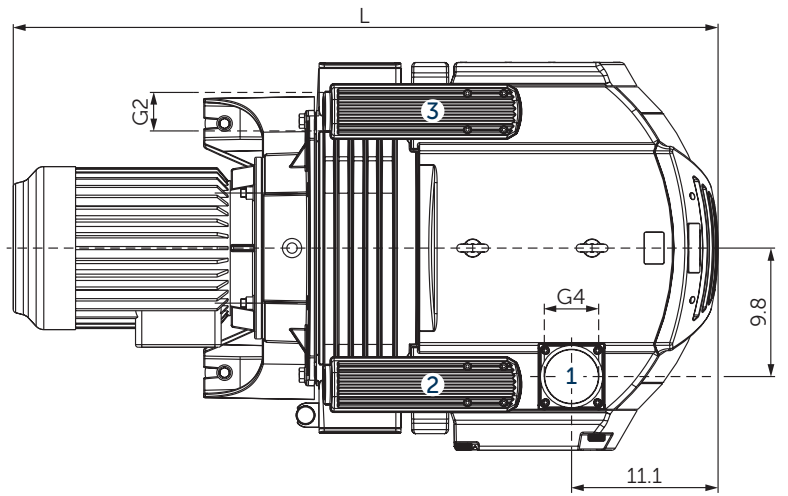
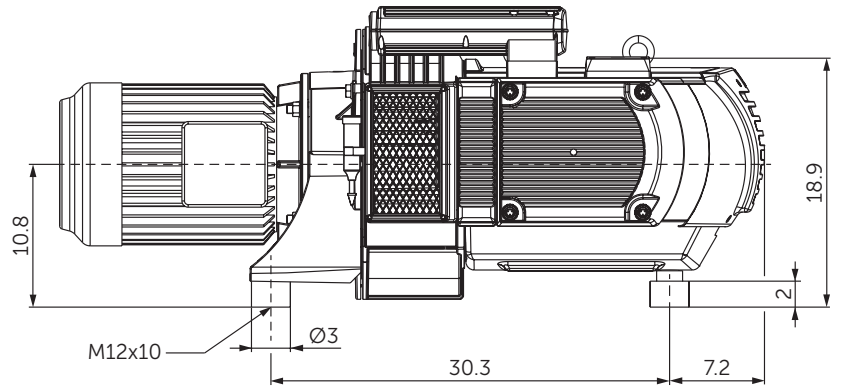
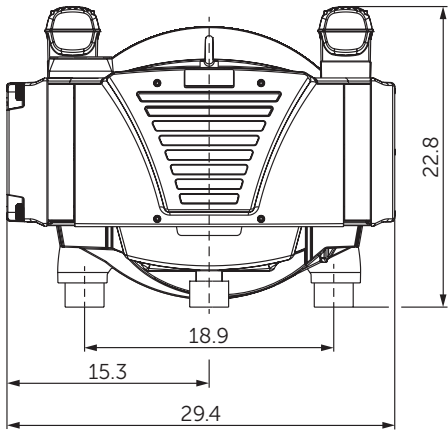

figure VXLF 2.250





- 1 Vacuum connection (G4)
- 2 Vacuum relief valve with silencer
- 3 Blow-off valve with silencer
 - Including integrated suction air filter
 - The motor illustration may vary.
 - Dimensions in inch

Suction air rate		Vacuum		Emission sound pressure level ¹⁾		Weight without motor
50 Hz	60 Hz	50 Hz	60 Hz	50 Hz	60 Hz	lbs
291	336	22.1	22.1	79	80	546.8

¹⁾ According to DIN EN ISO 3744 (KpA = 3 dB(A)), 39.4 inch distance, at medium load, both connection sides piped

3~ Motors												L	
#	50 Hz					60 Hz				Version	Weight lbs	inch	
	hp	V	rpm	A	hp	V	rpm	A					
01	14.8	Δ400	IE3	978	24.9	17.7	Δ460	IE3	1185	25.0	IP55 • ISO F • bimetal	359.4	58.2
							Δ400		1180	27.3			
02						17.7	YY230/Y460	IE3	1185	50.6/25.3	UL(E235514) • CSA CC329B	358.3	58.2
							YY208		1180	52.9	IP55 • ISO F • bimetal		
03						25.0	YY230/Y460	IE3	1183	69.1/34.6	UL(E235514) • CSA CC329B	358.3	58.3
							YY208		1180	72.3	IP55 • ISO F • bimetal		
04	14.8	Δ200/Y350	IE3	985	45.9/26.5	17.7	Δ220/Y380-400	IE3	1185	49.0/28.3-27.2	UL(E235514) • CSA CC329B	359.4	57.9
							Δ200/Y350		1177	52.8/30.5	IP55 • ISO F • bimetal		
05						17.7	Δ400/Y690	IE3	1185	27.8/15.9	UL(E235514) • CSA CC329B IP55 • ISO F • bimetal	359.4	58.2

- Current consumption and rotation speed may vary. Tolerance in each case -1.5/+2%

SERIES X: BECKER INNOVATION WITH TOP WARRANTY

Equipped with specially developed vanes, these oil-free rotary vane pumps distinguish themselves by high abrasion resistance, and with that extremely long service lives. Due to the low wear there is also minimal dust, so the series X pumps are perfectly suited for precision processes under clean room conditions.

This innovation branded by Becker is outstanding not only because of its 100 percent oil-free operation, excellent degree of efficiency and low power consumption.

In the area of sensitive vacuum, series X also guarantees precise low-pulsation air conduction.

Becker guarantees for these pumps a vane life-time of 20,000 operating hours or a maximum of 3 years. The enhanced longevity of X series pumps also extends service life intervals, and can cut out the need for frequent service visits with costly pump failures now no longer an issue.



ADVANTAGES

- Quick, clean and quiet
- Oil-free
- Wear resistant
- Energy saving
- Long-life reliability

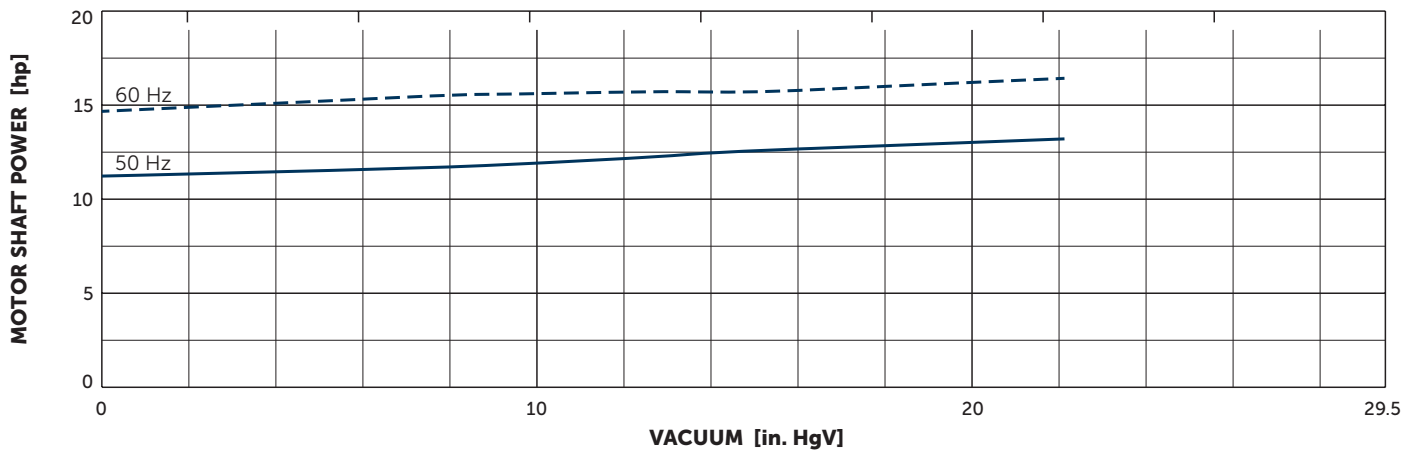
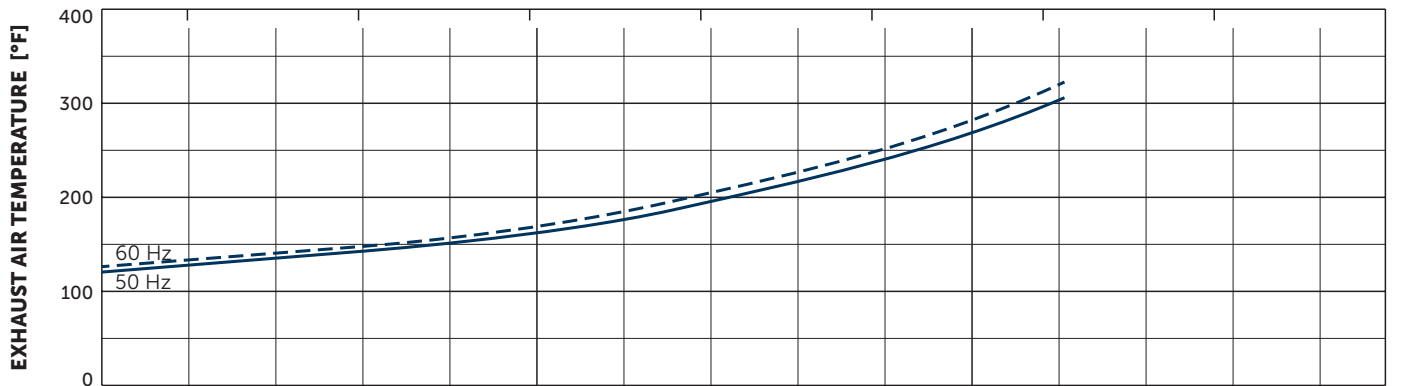
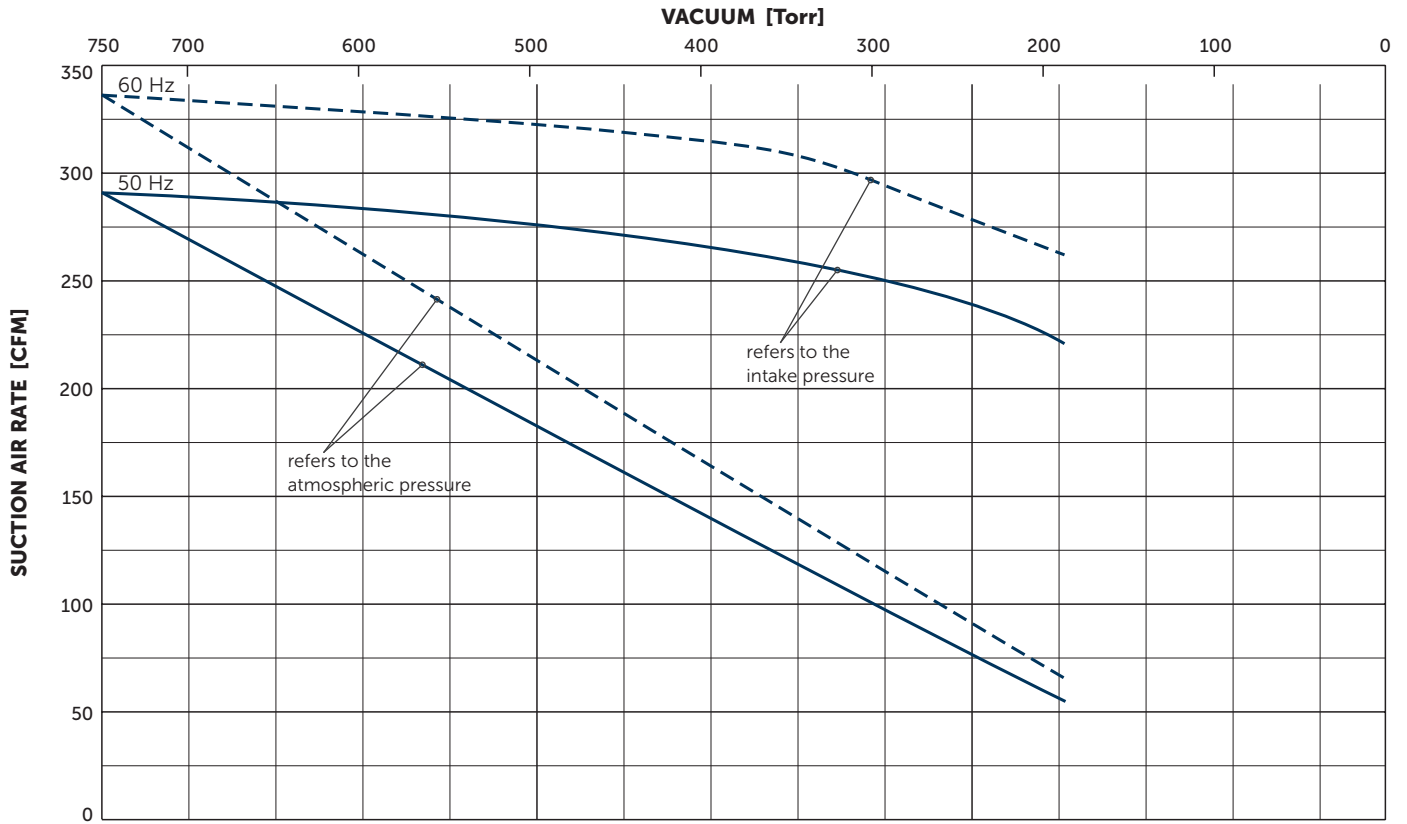

Reference data (atmosphere): 0 in. HgV, 68°F; Tolerance: ±5%

VARIAIR AND ACCESSORIES

- **VARIAIR VXLF 2.500/0-400** with frequency inverter¹⁾
- Integrated non return valve
- External suction filter¹⁾
- Sound proof box SH 12¹⁾



VARIAIR VXLF 2.500/0-400



Example for an external suction filter



Sound proof box SH 12

¹⁾ See separate data sheet

- Possible combinations on request

MAKE IT BECKER.

