

DATA SHEET

# VXLF 2.400

# ROTARY VANE VACUUM PUMPS

oil-free

air-cooled

---

**MAKE IT BECKER.**

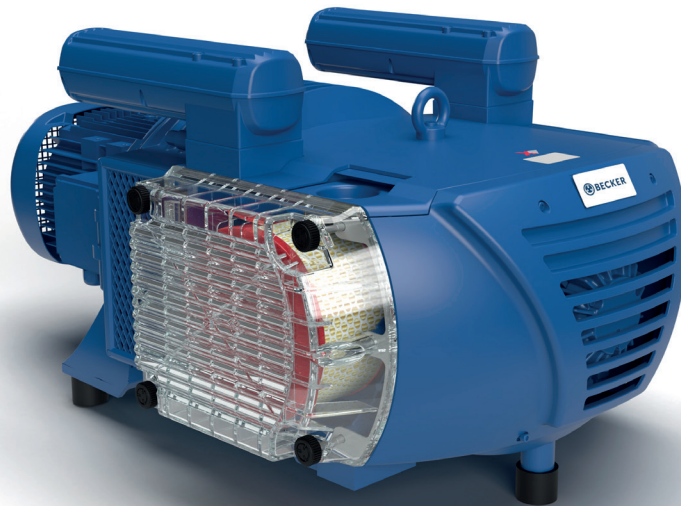
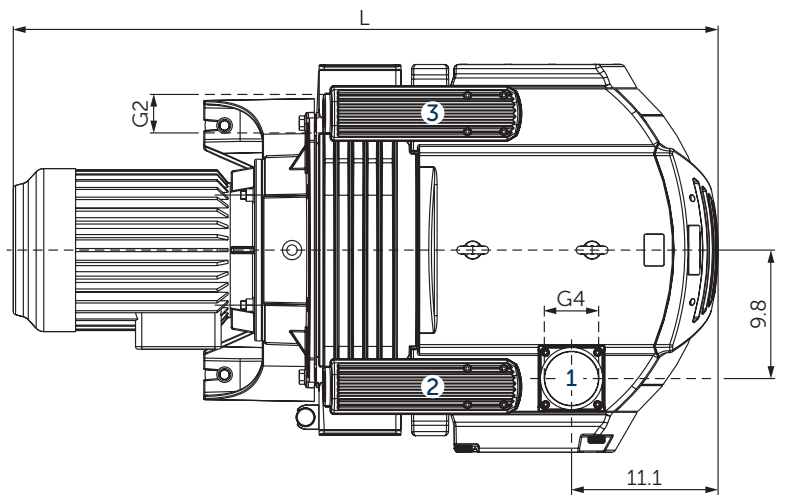
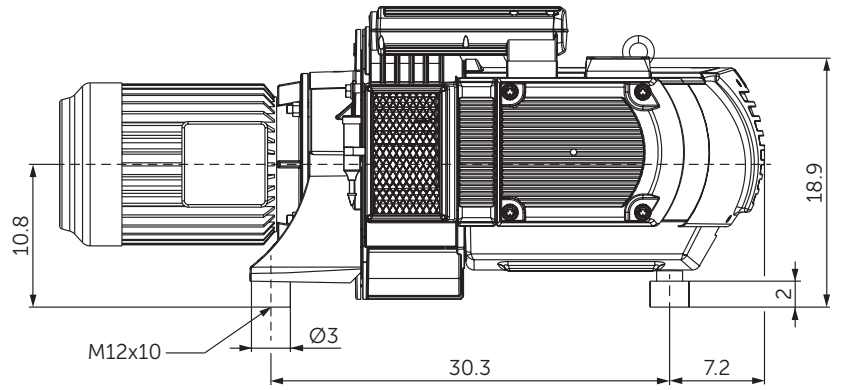
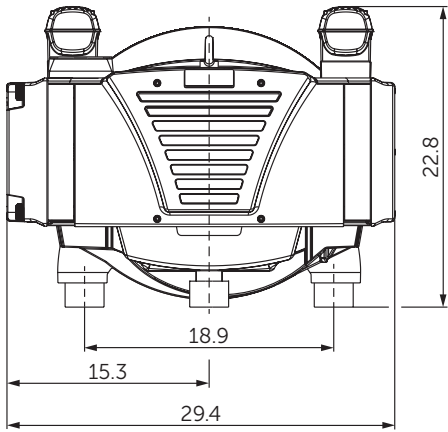

figure VXLF 2.250





- 1 Vacuum connection (G4)
- 2 Vacuum relief valve with silencer
- 3 Blow-off valve with silencer
  - Including integrated suction air filter
  - The motor illustration may vary.
  - Dimensions in inch

Suction air rate		Vacuum		Emission sound pressure level <sup>1)</sup>		Weight without motor
50 Hz	60 Hz	50 Hz	60 Hz	50 Hz	60 Hz	lbs
230	270	23.6	23.6	77	79	546.8

<sup>1)</sup> According to DIN EN ISO 3744 (KpA = 3 dB(A)), 39.4 inch distance, at medium load, both connection sides piped

3~ Motors												L	
#	50 Hz					60 Hz				Version	Weight lbs	inch	
	hp	V	rpm	A	hp	V	rpm	A					
01	10.1	Δ400	IE3	738	19.9	12.1	Δ460 Δ400	IE3	886 881	20.1 21.4	UL(E235514) • CSA CC329B IP55 • ISO F • bimetal	390.3	58.2
02						12.1	YY230/Y460 YY208	IE3	888 886	43.4/21.7 55.3	UL(E235514) • CSA CC329B IP55 • ISO F • bimetal	390.3	58.2
03						15.0	208–230/460		880	42.9–38.8/19.4	NEMA IP55 • ISO F	417.2	58.2
04						17.7	YY230/Y460 YY208	IE3	884 880	59.3/29.5 61.3	UL(E235514) • CSA CC329B IP55 • ISO F • bimetal	449.9	60.8
05	10.1	Δ200/Y350	IE3	736	37.2/21.5	12.1	Δ220/Y380–400 Δ200/Y350	IE3	882 876	39.1/22.6–22 42.9/24.8	UL(E235514) • CSA CC329B IP55 • ISO F • bimetal	390.3	58.2
06						12.1	Δ400/Y690	IE3	878	22.3/12.9	UL(E235514) • CSA CC329B IP55 • ISO F • bimetal	390.3	58.2

- Current consumption and rotation speed may vary. Tolerance in each case -1.5/+2%

#### SERIES X: BECKER INNOVATION WITH TOP WARRANTY

Equipped with specially developed vanes, these oil-free rotary vane pumps distinguish themselves by high abrasion resistance, and with that extremely long service lives. Due to the low wear there is also minimal dust, so the series X pumps are perfectly suited for precision processes under clean room conditions.

This innovation branded by Becker is outstanding not only because of its 100 percent oil-free operation, excellent degree of efficiency and low power consumption.

In the area of sensitive vacuum, series X also guarantees precise low-pulsation air conduction.

Becker guarantees for these pumps a vane life-time of 20,000 operating hours or a maximum of 3 years. The enhanced longevity of X series pumps also extends service life intervals, and can cut out the need for frequent service visits with costly pump failures now no longer an issue.



#### ADVANTAGES

- Quick, clean and quiet
- Oil-free
- Wear resistant
- Energy saving
- Long-life reliability

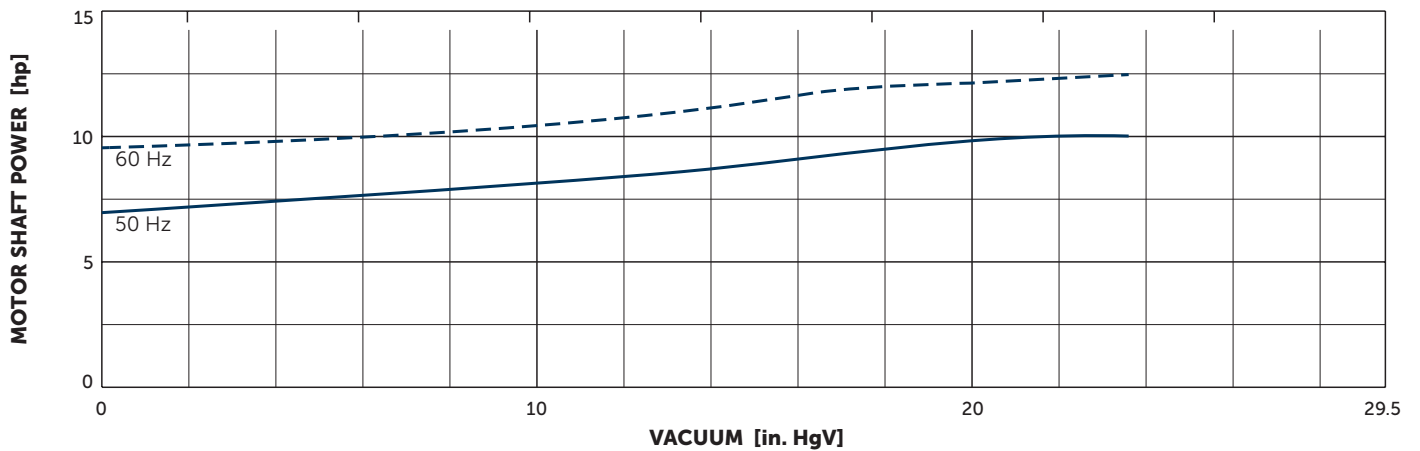
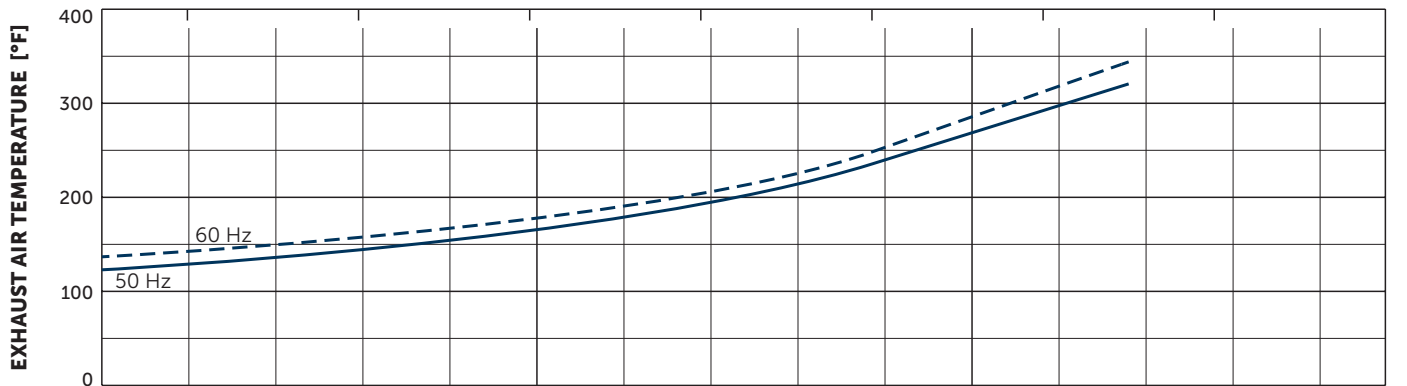
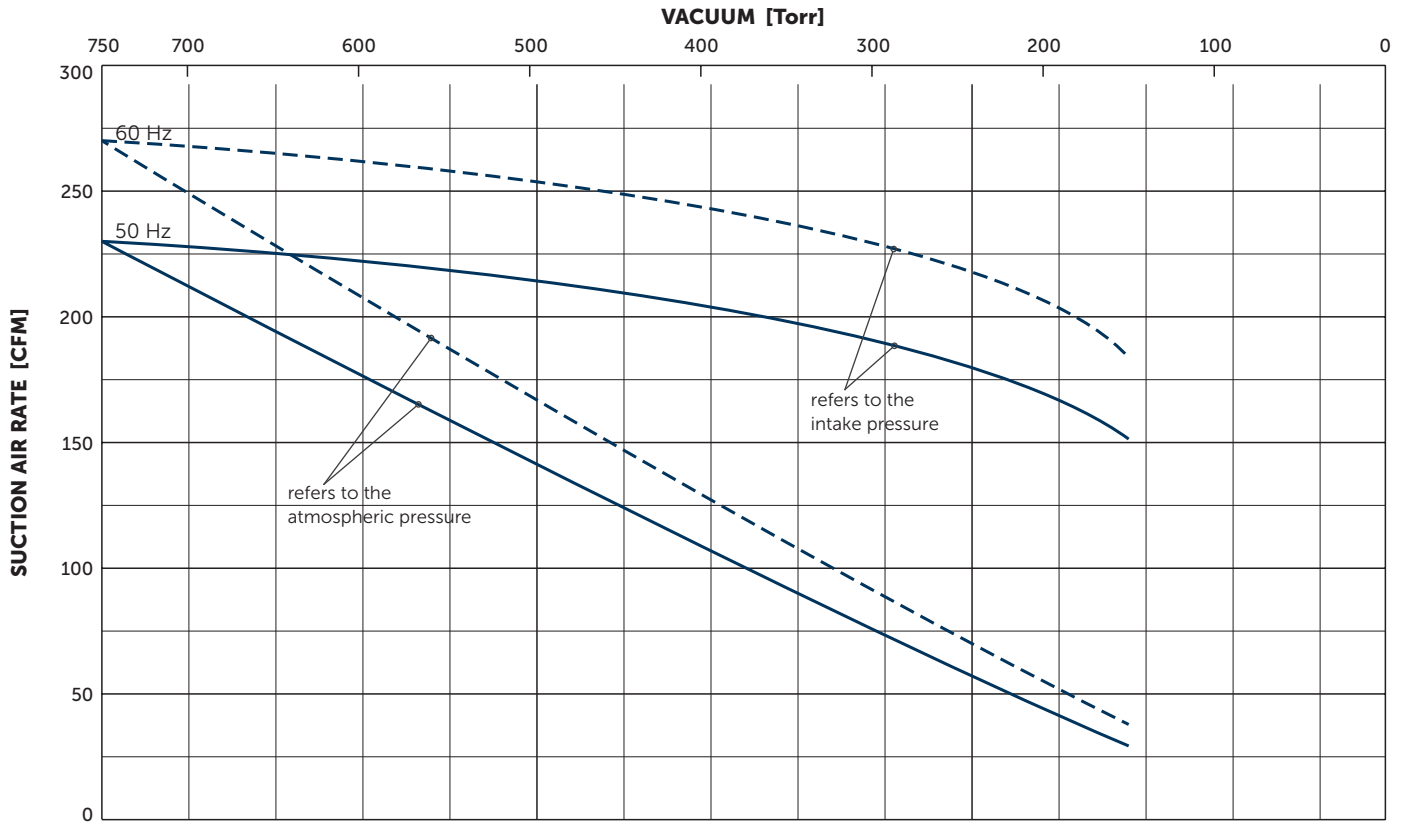

Reference data (atmosphere): 0 in. HgV, 68°F; Tolerance: ±5%

## **+** VARIANTS AND ACCESSORIES

- Integrated non return valve
- External suction filter<sup>1)</sup>
- Sound proof box SH 12<sup>1)</sup>



Example for an external suction filter



Sound proof box SH 12

<sup>1)</sup> See separate data sheet

- Possible combinations on request

**MAKE IT BECKER.**

