

DATA SHEET

# VARIAIR VXLF 2.250/0-400

## ROTARY VANE VACUUM PUMPS

oil-free and air-cooled  
with VARIAIR frequency inverter

**MAKE IT BECKER.**



**VARIAIR**  
UNIT

 **BECKER**

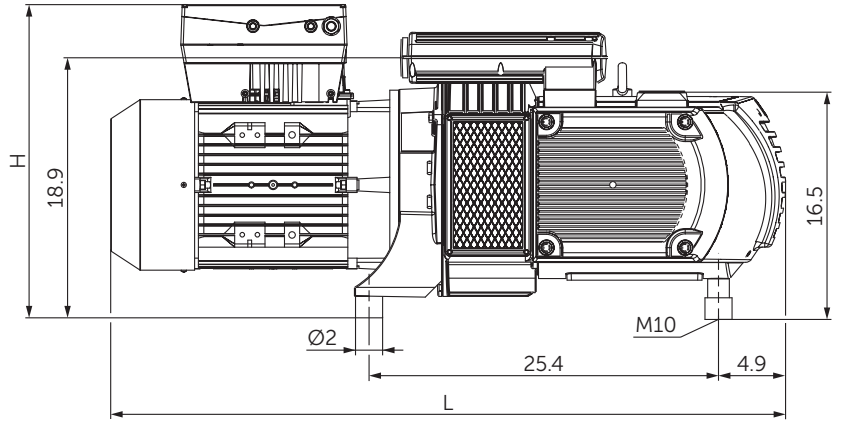
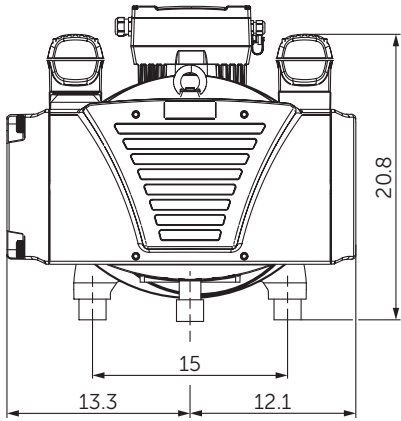

- 1 Vacuum connection (G2½)
- 2 Vacuum relief valve with silencer
- 3 Blow-off valve with silencer
- Including integrated suction air filter
- The motor illustration may vary.
- Dimensions in inch

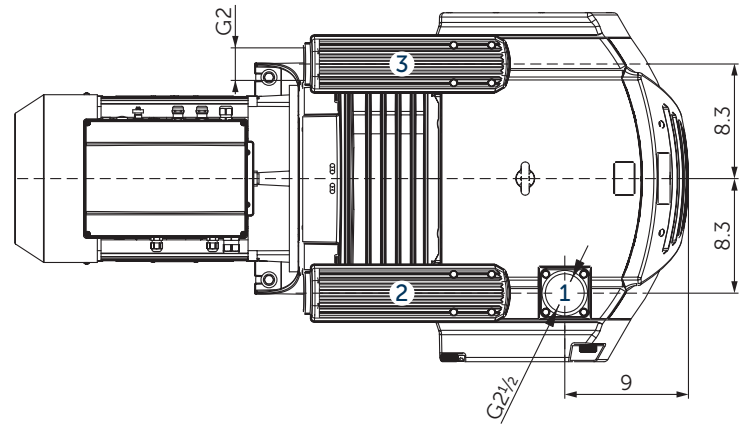

(M)	H	L
	mm [inch]	mm [inch]
42969654300114TA	500 [19,7]	1200 [47,3]
42969601300000CT	580 [22,9]	1250 [49,3]

Suction air rate	Vacuum	Frequency	Emission sound pressure level <sup>1)</sup>	Weight		
CFM max.	in. HgV max.	Hz	dB(A) max.	lbs	Frequency inverter VAU7.5/3	A max.
164.7	23.6	30-60	79	≈595.4	10.1 hp 400-480 V ±10% 50/60 Hz	20

<sup>1)</sup> According to DIN EN ISO 3744 (KpA = 3 dB(A)), 39.4 inch distance, at medium load, both connection sides piped

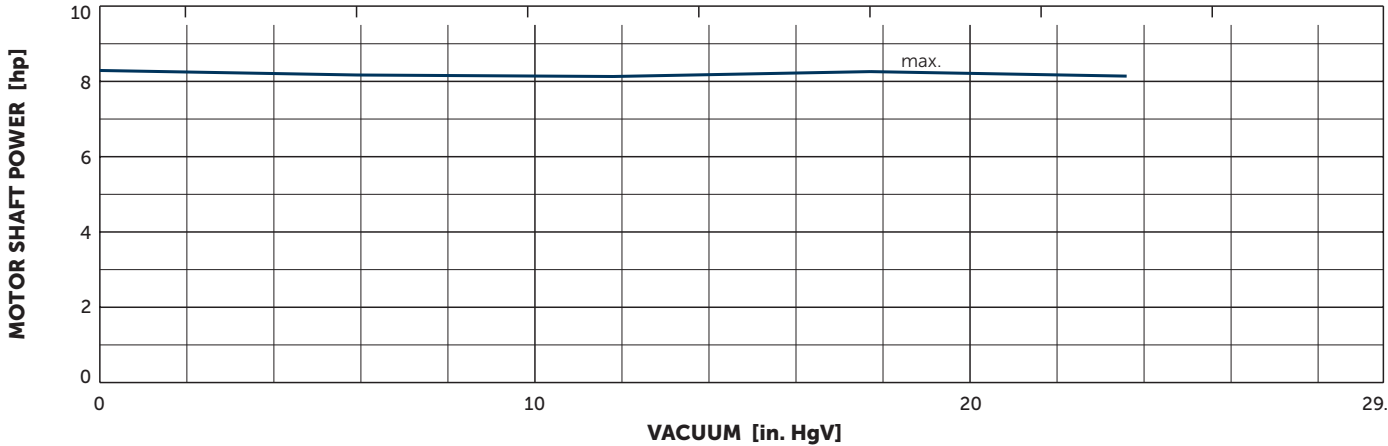
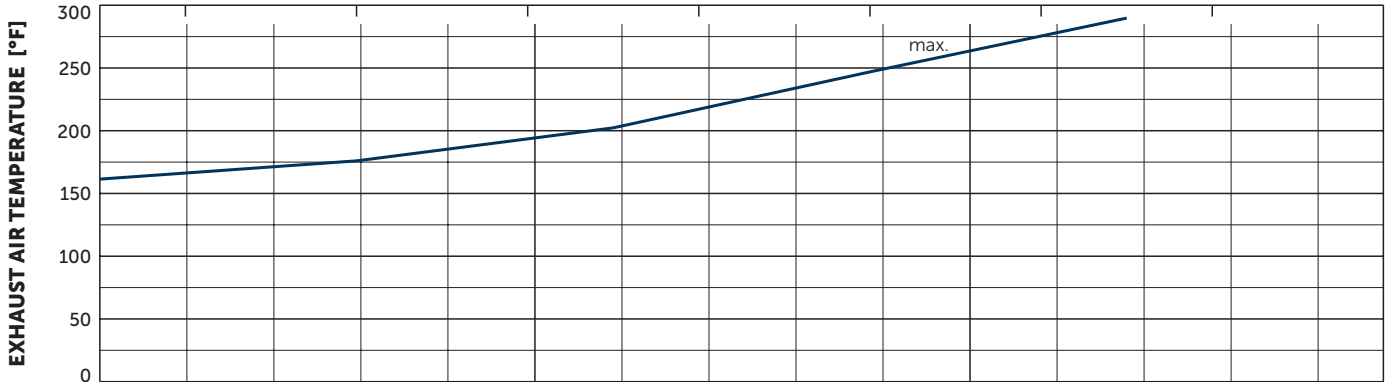
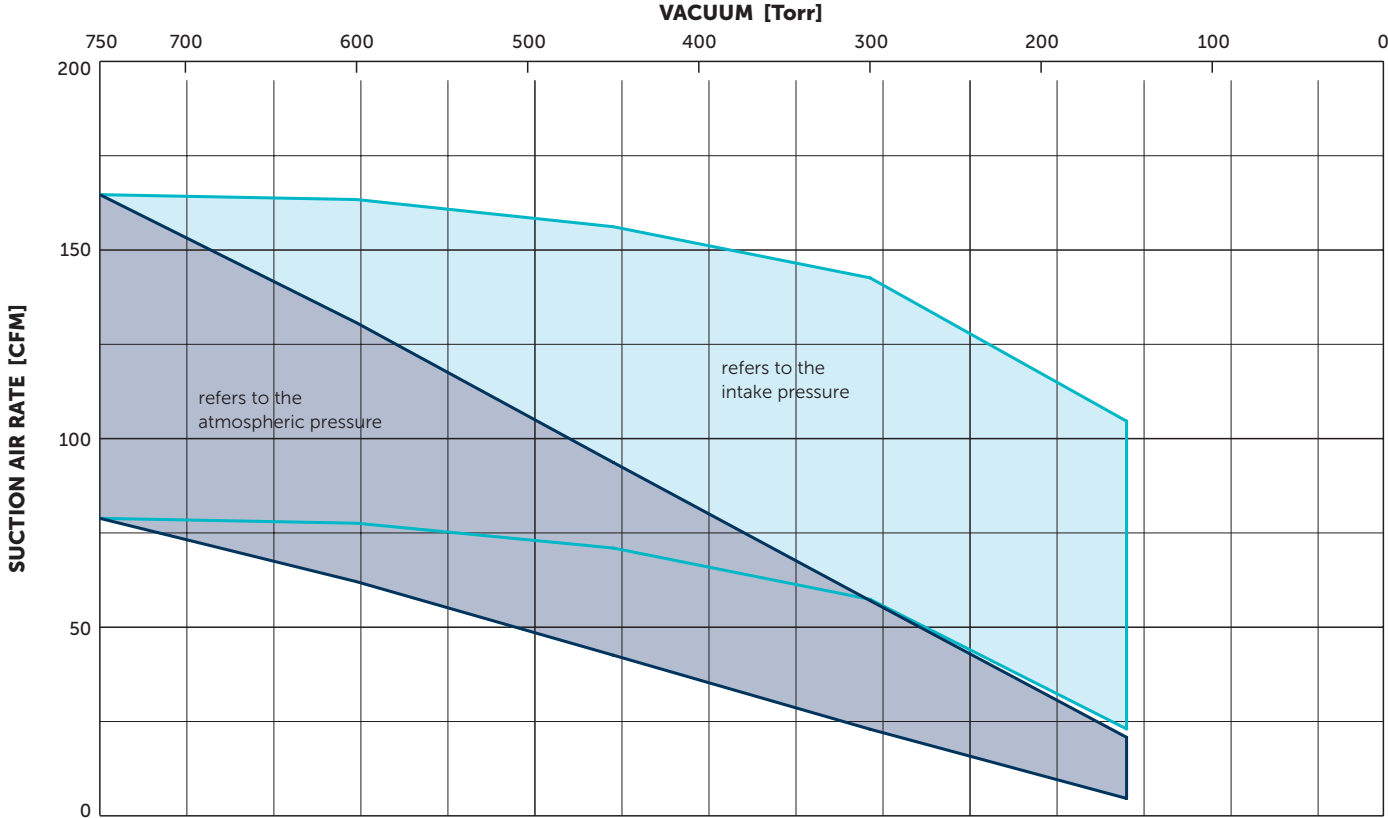

Reference data (atmosphere): 0 in. HgV, 68°F; Tolerance: ±5%



**MAKE IT BECKER.**

