

DATA SHEET

VXLF 2.200

ROTARY VANE VACUUM PUMPS

oil-free

air-cooled

MAKE IT BECKER.

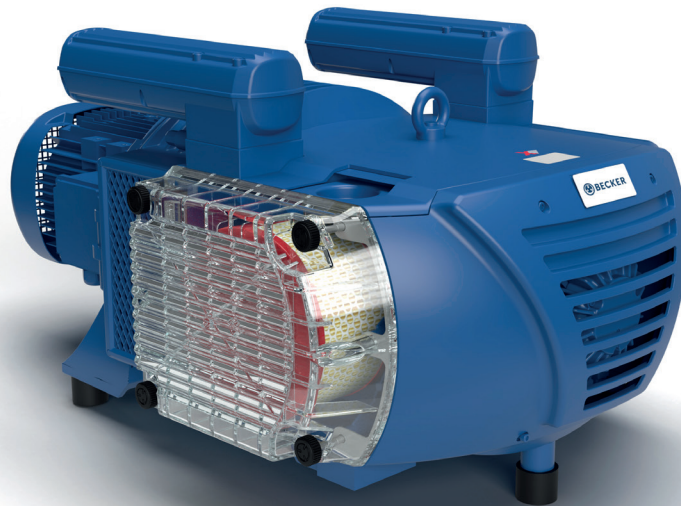

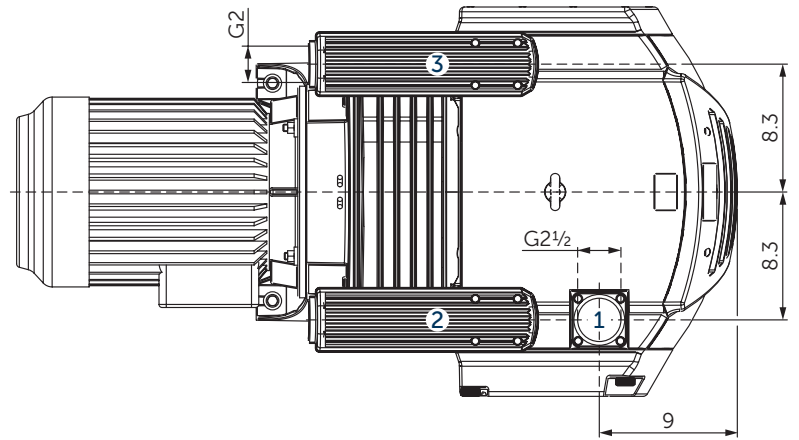
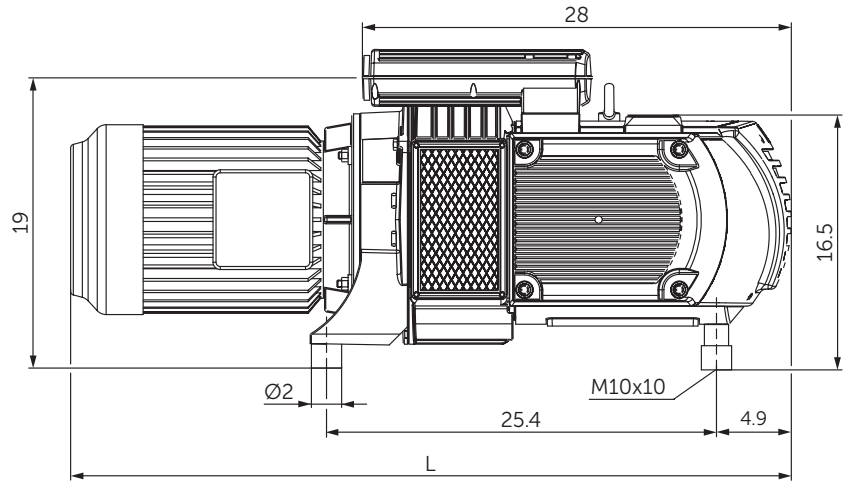
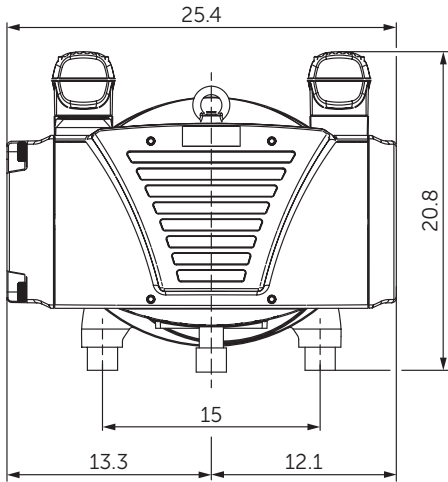

- 1 Vacuum connection (G2½)
- 2 Vacuum relief valve with silencer
- 3 Blow-off valve with silencer
 - Including integrated suction air filter
 - The motor illustration may vary.
 - Dimensions in inch

Suction air rate		Vacuum		Emission sound pressure level ¹⁾		Weight without motor
50 Hz	60 Hz	50 Hz	60 Hz	50 Hz	60 Hz	lbs
105	128	23.6	23.6	75	77	333

¹⁾ According to DIN EN ISO 3744 (KpA = 3 dB(A)), 39.4 inch distance, at medium load, both connection sides piped

3~ Motors												L	
#	50 Hz					60 Hz				Version	Weight lbs	inch	
	hp	V	rpm	A	hp	V	rpm	A					
01	5.4	Δ230/Y400	IE3	735	19.6/11.0	6.4	Δ265/Y460	IE3	882	19.6/11.3	IP55 • ISO F • bimetal	235.9	46.3
							Δ230/Y400		875	20.4/11.8			
02						6.4	YY230/Y460	IE3	883	22.4/11.2	UL(E235514) • CSA CC329B	251.4	46.3
							YY208		879	22.7	IP55 • ISO F • bimetal		
03	5.4	Δ200/Y350	IE3	730	22.0/12.7	6.4	Δ220/Y380-400	IE3	876	23.0/13.3-12.5	UL(E235514) • CSA CC329B	233.7	46.3
							Δ200/Y350		871	23.0/13.3	IP55 • ISO F • bimetal		
04						6.4	Δ400/Y690	IE3	883	13.0/7.5	UL(E235514) • CSA CC329B IP55 • ISO F • bimetal	251.4	46.3

• Current consumption and rotation speed may vary. Tolerance in each case -1.5/+2%

SERIES X: BECKER INNOVATION WITH TOP WARRANTY

Equipped with specially developed vanes, these oil-free rotary vane pumps distinguish themselves by high abrasion resistance, and with that extremely long service lives. Due to the low wear there is also minimal dust, so the series X pumps are perfectly suited for precision processes under clean room conditions.

This innovation branded by Becker is outstanding not only because of its 100 percent oil-free operation, excellent degree of efficiency and low power consumption.

In the area of sensitive vacuum, series X also guarantees precise low-pulsation air conduction.

Becker guarantees for these pumps a vane life-time of 20,000 operating hours or a maximum of 3 years. The enhanced longevity of X series pumps also extends service life intervals, and can cut out the need for frequent service visits with costly pump failures now no longer an issue.



ADVANTAGES

- Quick, clean and quiet
- Oil-free
- Wear resistant
- Energy saving
- Long-life reliability

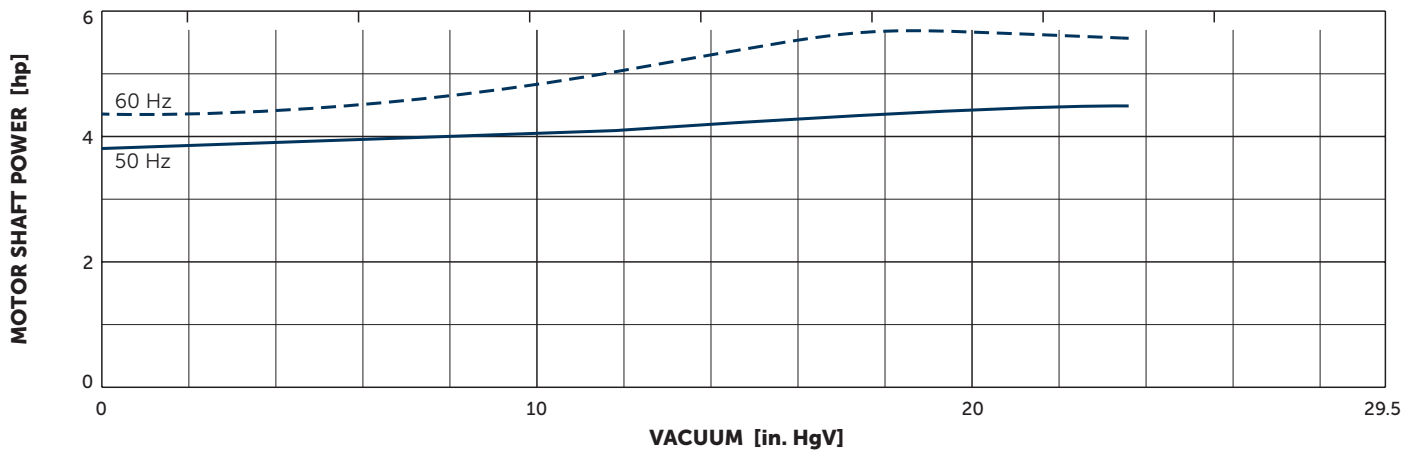
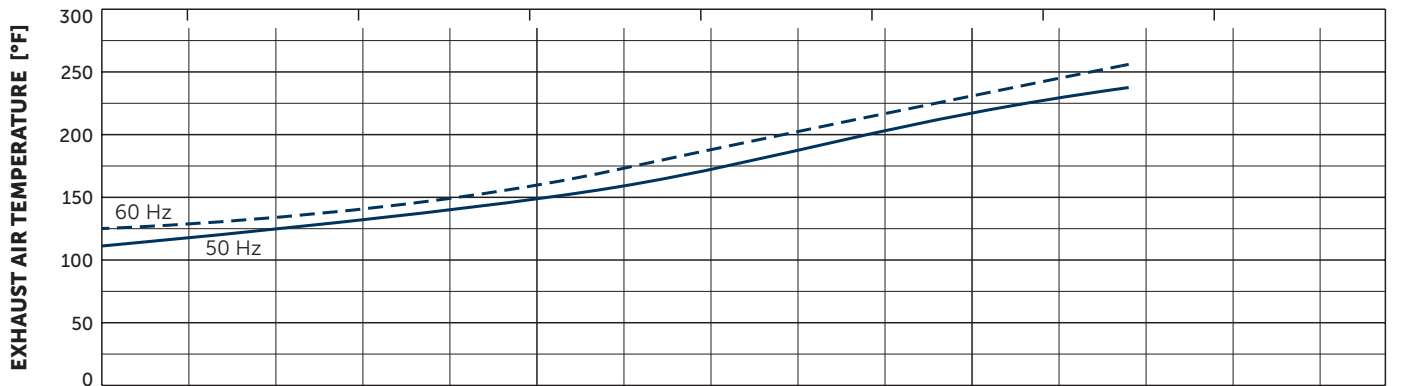
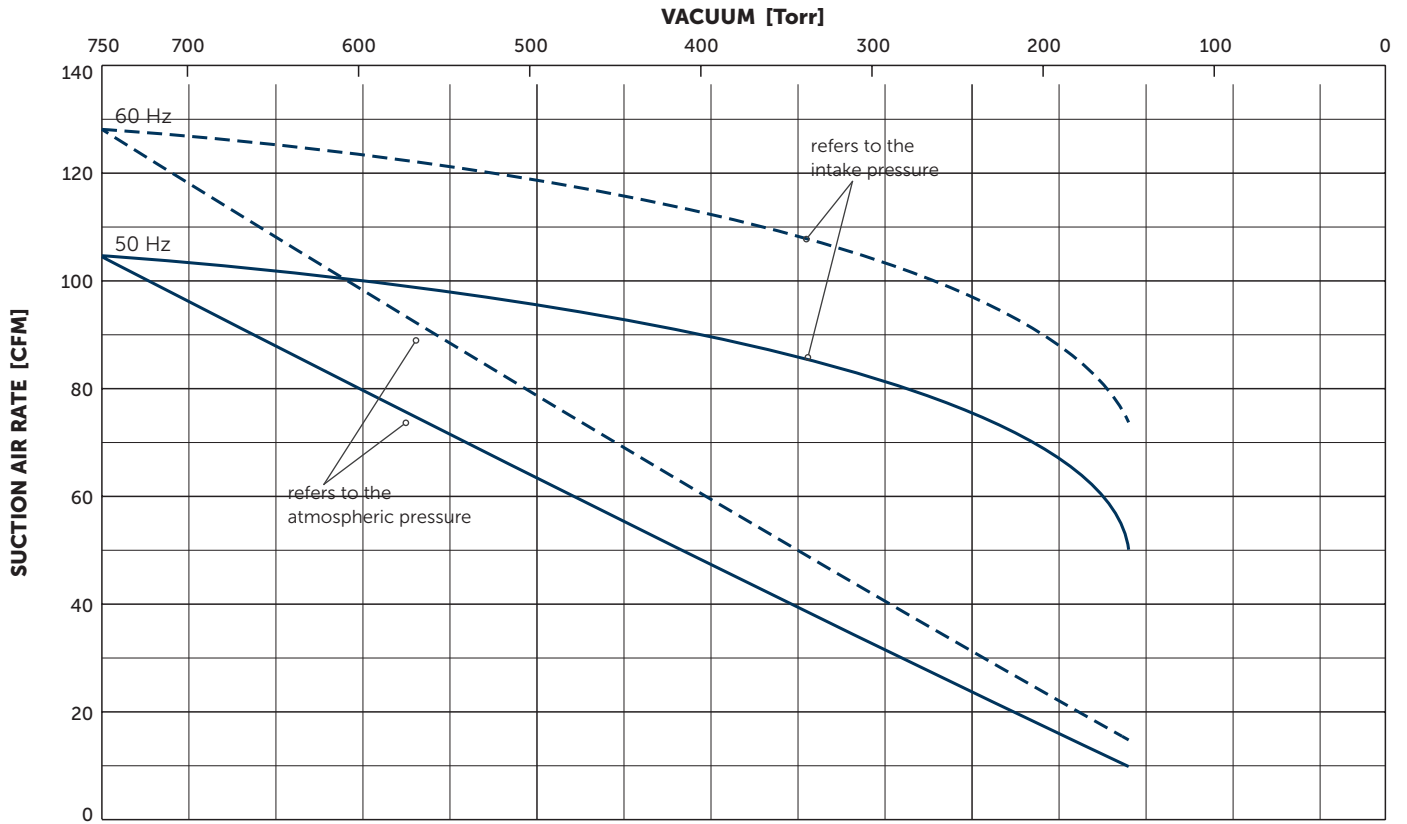

Reference data (atmosphere): 0 in. HgV, 68°F; Tolerance: ±5%

+ VARIANTS AND ACCESSORIES

- Integrated non return valve
- External suction filter¹⁾
- Sound proof box SH 10¹⁾



Example for an external suction filter



Sound proof box SH 10

¹⁾ See separate data sheet

- Possible combinations on request



MAKE IT BECKER.