

DATA SHEET

VARIAIR VXLF 2.500/0-400

ROTARY VANE VACUUM PUMPS

oil-free and air-cooled
with VARIAIR frequency inverter

MAKE IT BECKER.



figure VARIAIR VXLF 2.250/0-400

VARIAIR
UNIT

 **BECKER**

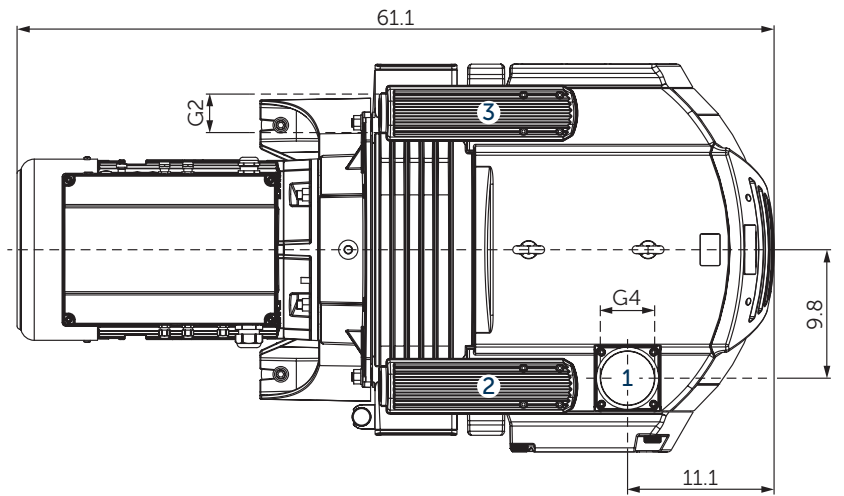
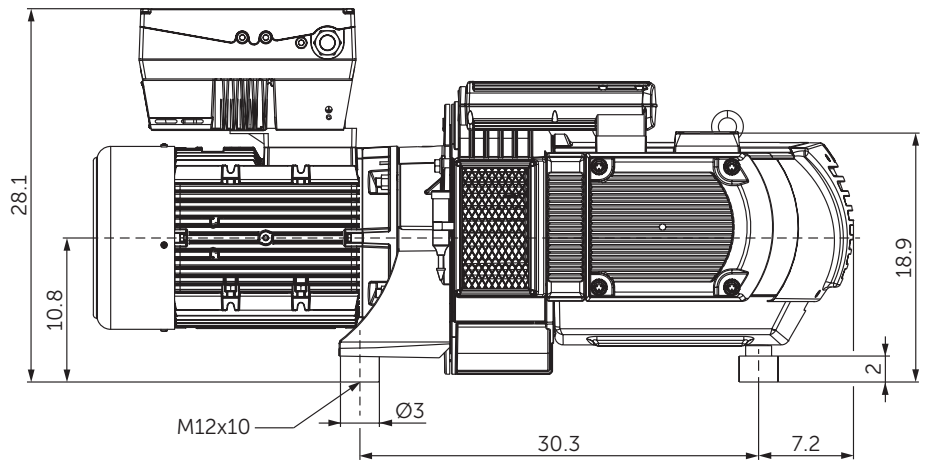
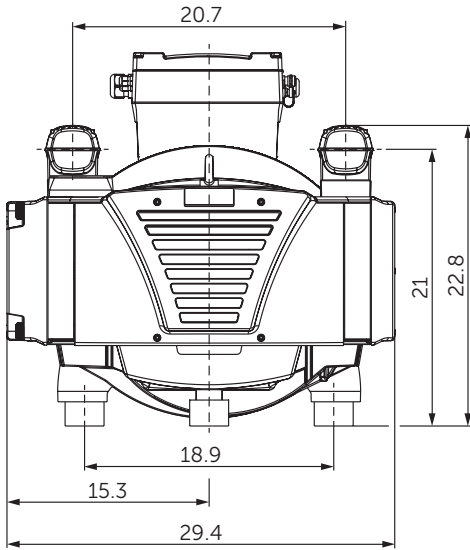

- 1 Vacuum connection (G4)
- 2 Vacuum relief valve with silencer
- 3 Blow-off valve with silencer
- Including integrated suction air filter
- The motor illustration may vary.
- Dimensions in inch

Suction air rate	Vacuum	Frequency	Emission sound pressure level ¹⁾	Weight	Frequency inverter VAU11-22/3	
CFM max.	in. HgV max.	Hz	dB(A) max.	lbs		A max.
329	22.1	60	80	981.2	14.8–29.5 hp 400–480 V ±10% 50/60 Hz	32

¹⁾ According to DIN EN ISO 3744 (KpA = 3 dB(A)), 39.4 inch distance, at medium load, both connection sides piped

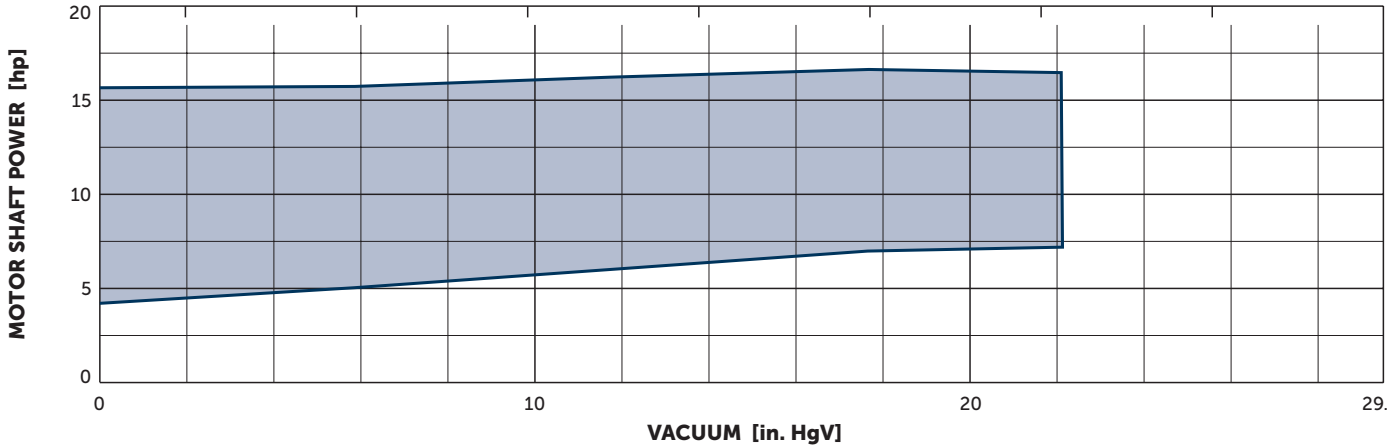
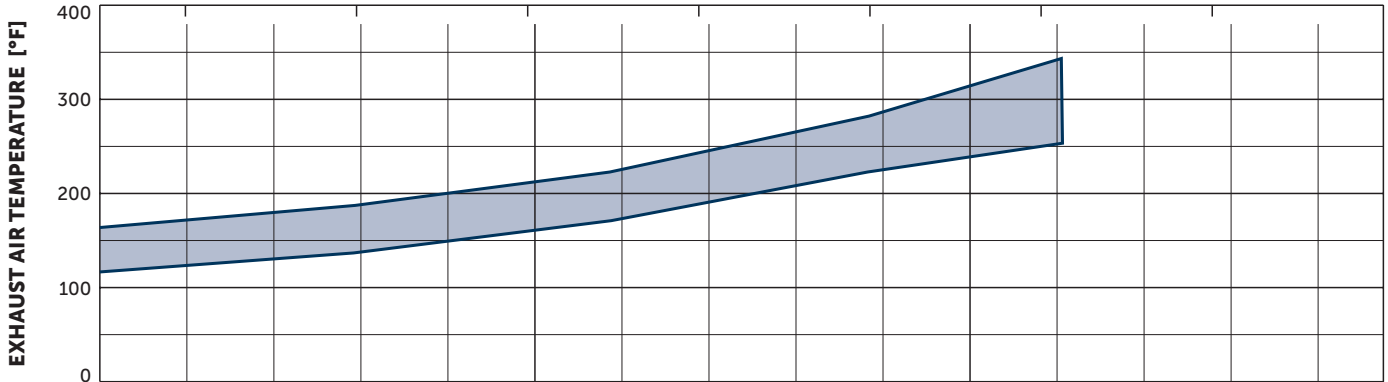
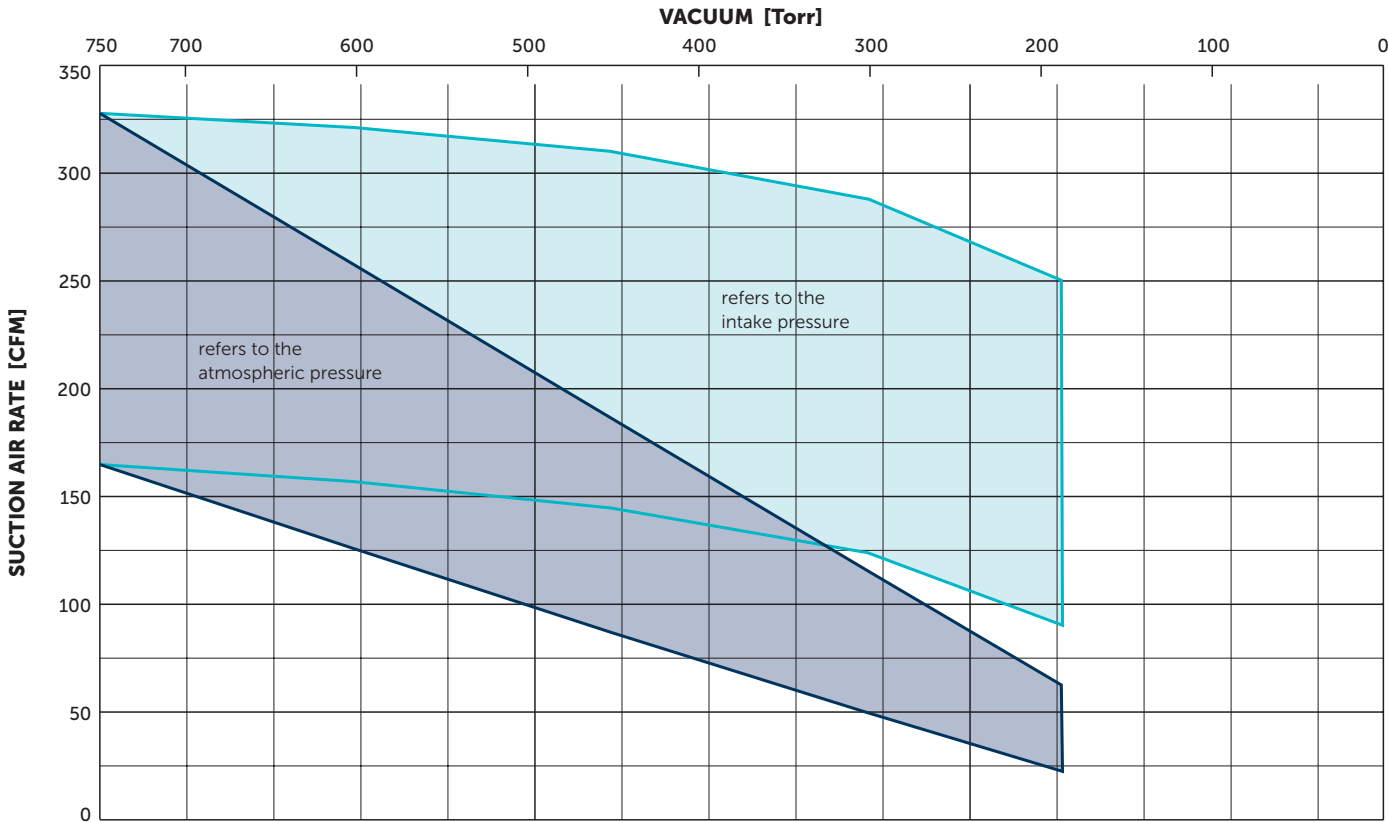

Reference data (atmosphere): 0 in. HgV, 68°F; Tolerance: ±5%

MAKE IT BECKER.

