

DATA SHEET

VARIAIR SV 500/1

SIDE CHANNEL VACUUM PUMPS

single stage, air-cooled
frequency inverter

MAKE IT BECKER.



VARIAIR
UNIT

 **BECKER**

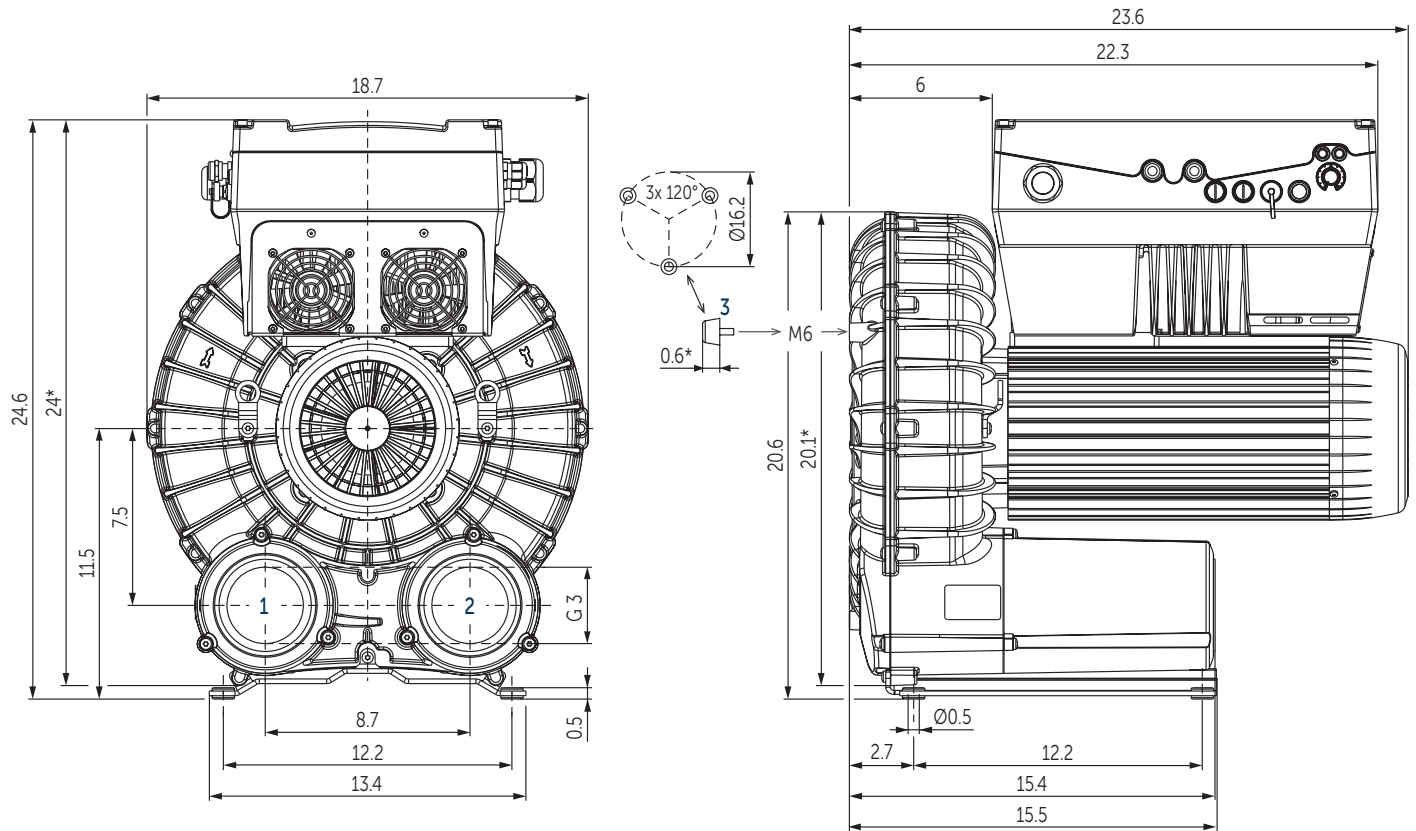

- 1 Vacuum connection (G 3)
- 2 Pressure connection (G 3)
- 3 Rubber buffer position (optional)
- * Device dimensions without pedestal (optional) under the silencer
- Dimensions in inch

Suction air rate	Vacuum		Frequency	Emission sound pressure level ¹⁾	Weight		
	CFM max.	in. H ₂ O max.					
588	148.7	10.9	10–100	80.6	214.9	14.8–29.5 400–480 V ±10% 50/60 Hz	35

¹⁾ According to DIN EN ISO 11203, accuracy class of measurement: class 2, extended measurement uncertainty: 3 dB 39.4 inch distance, at medium load, both connection sides piped

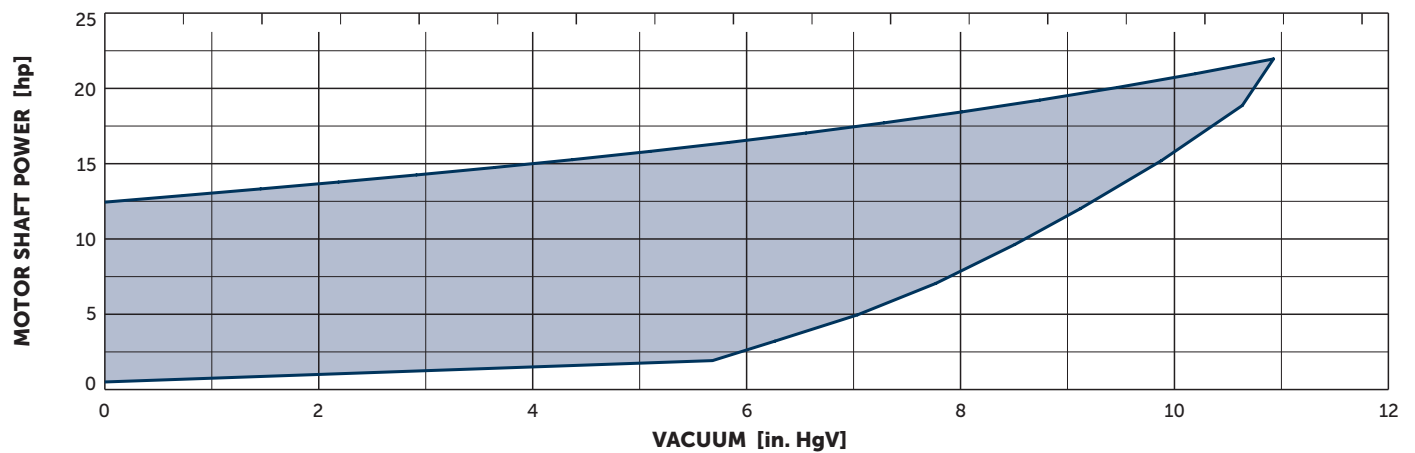
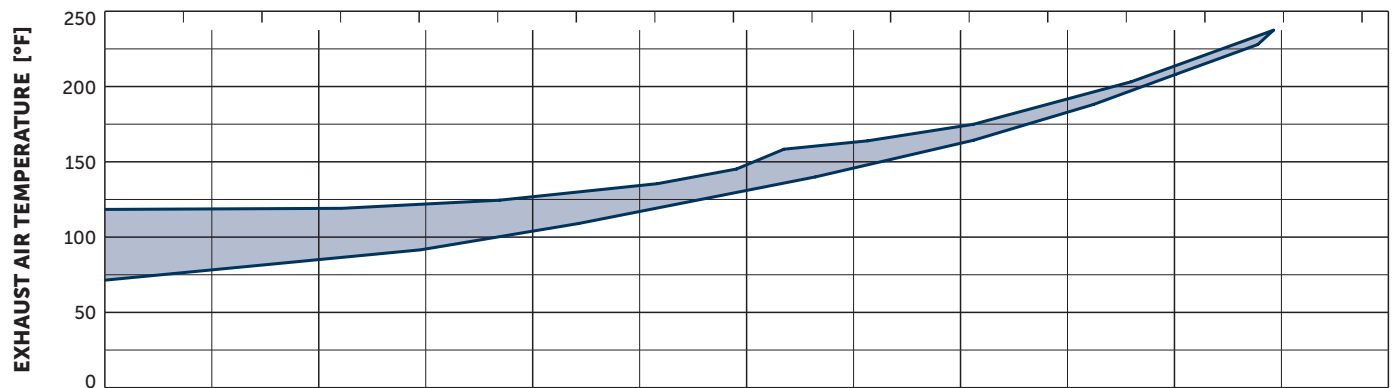
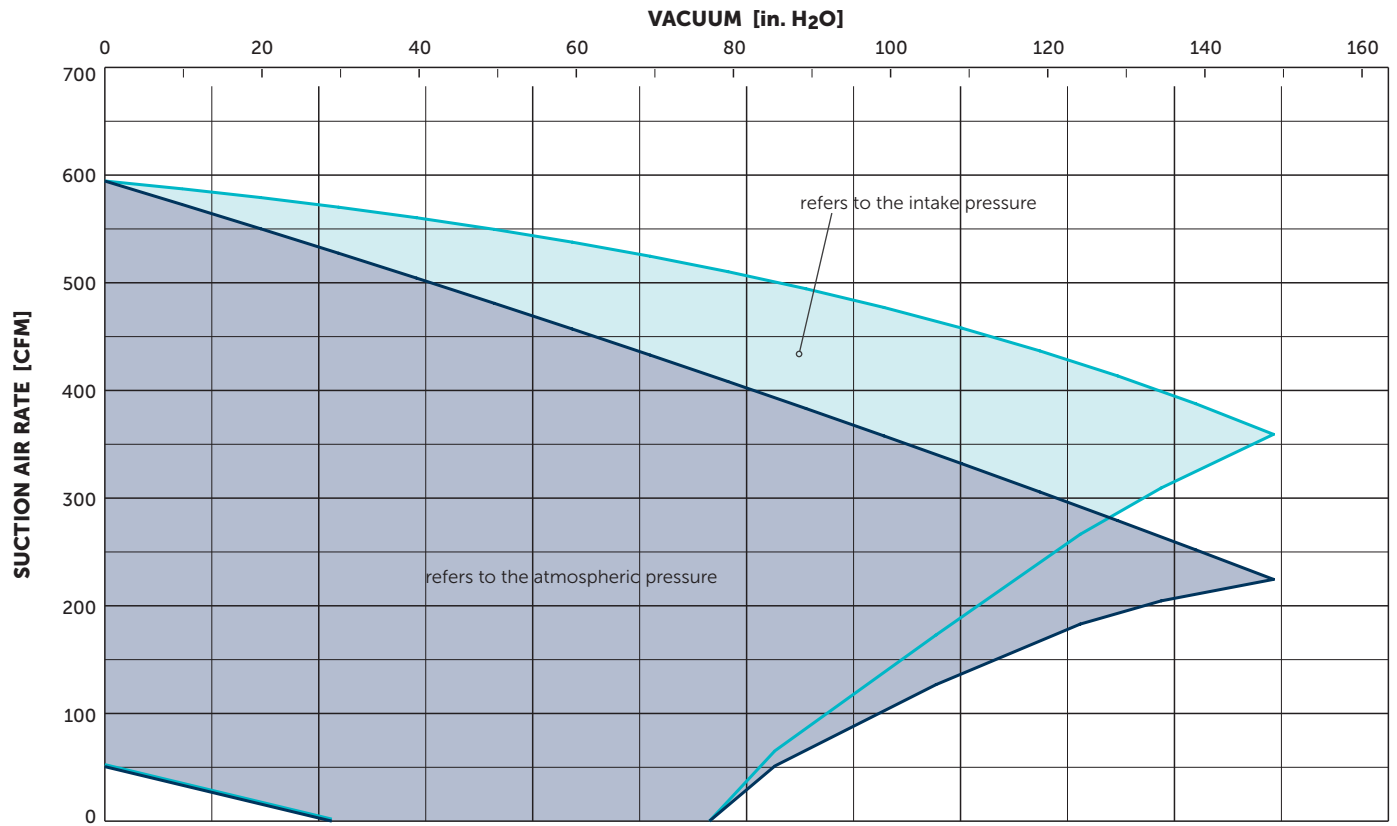

Reference data (atmosphere): 0 in. HgV, 68°F; Tolerance: ±10%
 Temperature: Ambient air 14°F ... 104°F, Inlet air 32°F ... 104°F



MAKE IT BECKER.