

DATA SHEET

KVX 3.60

ROTARY VANE VACUUM PUMPS

oil-free

air-cooled

MAKE IT BECKER.



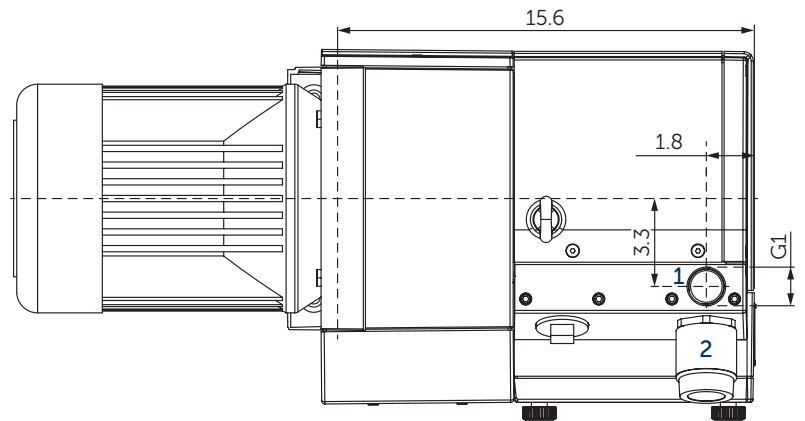
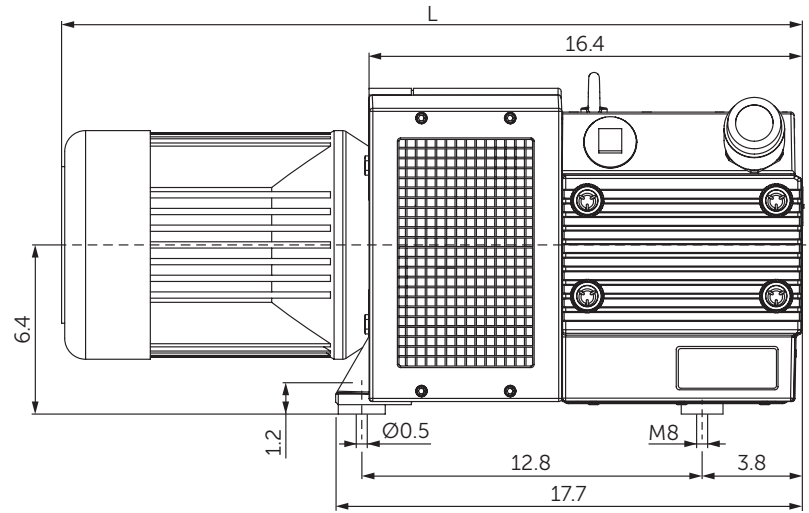
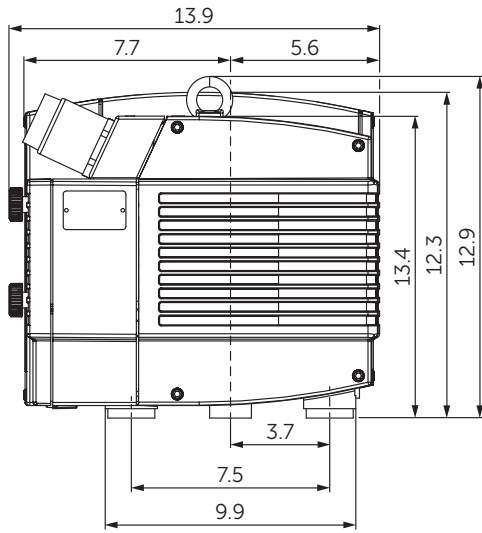

- 1 Vacuum connection (G1)
- 2 Vacuum regulating valve
- Including integrated suction air filter and blow of valve
- The motor illustration may vary.
- Dimensions in inch

Suction air rate		Vacuum		Emission sound pressure level ¹⁾		Weight w/o motor
CFM		in. HgV		dB(A)		lbs
50 Hz	60 Hz	50 Hz	60 Hz	50 Hz	60 Hz	
32	39	26.6	26.6	71	73	104

¹⁾ According to DIN EN ISO 3744 (KpA = 3 dB(A)), 39.4 inch distance, at medium load, both connection sides piped

3~ Motors ¹⁾												L	
#	50 Hz					60 Hz				Version	Weight lbs	inch	
	hp	V	rpm	A	hp	V	rpm	A					
01	3.0	Δ230/Y400	IE3	1440	8.2/4.8	3.5	Δ265/Y460	IE3	1735	8.2/4.8	IP55 • ISO F • bimetal	54.0	27.7
							Δ230/Y400		1705	9.0/5.2			
02						3.5	YY230/Y460	IE3	1763	9.3/4.6	UL(E365362) • CSA CC334B IP55 • ISO F • bimetal	81.6	29.4
							YY208		1754	9.7			
03	3.0	Δ200/Y350	IE3	1470	10.4/6.0	3.5	Δ220/Y380-400	IE3	1760	10.0/5.8–5.8	UL(E365362) • CSA CC334B IP55 • ISO F • bimetal	81.6	29.4
							Δ200/Y350		1755	10.2/5.9			
04						3.5	Δ400/Y690	IE3	1760	5.3/3.1	UL(E365362) • CSA CC334B IP55 • ISO F • bimetal	81.6	29.4
05						3.0	YY230/Y460	IE3	1800	8.0/4.0	UL • CSA • NEMA ISO F	95.0	28.5
							YY208		1730	8.8			

• Current consumption and rotation speed may vary. Tolerance in each case -1.5/+2%

SERIES X: BECKER INNOVATION WITH TOP WARRANTY

Equipped with specially developed vanes, these oil-free rotary vane pumps distinguish themselves by high abrasion resistance, and with that extremely long service lives. Due to the low wear there is also minimal dust, so the series X pumps are perfectly suited for precision processes under clean room conditions.

This innovation branded by Becker is outstanding not only because of its 100 percent oil-free operation, excellent degree of efficiency and low power consumption.

In the area of sensitive vacuum, series X also guarantees precise low-pulsation air conduction.

Becker guarantees for these pumps a vane life-time of 20,000 operating hours or a maximum of 3 years. The enhanced longevity of X series pumps also extends service life intervals, and can cut out the need for frequent service visits with costly pump failures now no longer an issue.



ADVANTAGES

- Quick, clean and quiet
- Oil-free
- Wear resistant
- Energy saving
- Long-life reliability

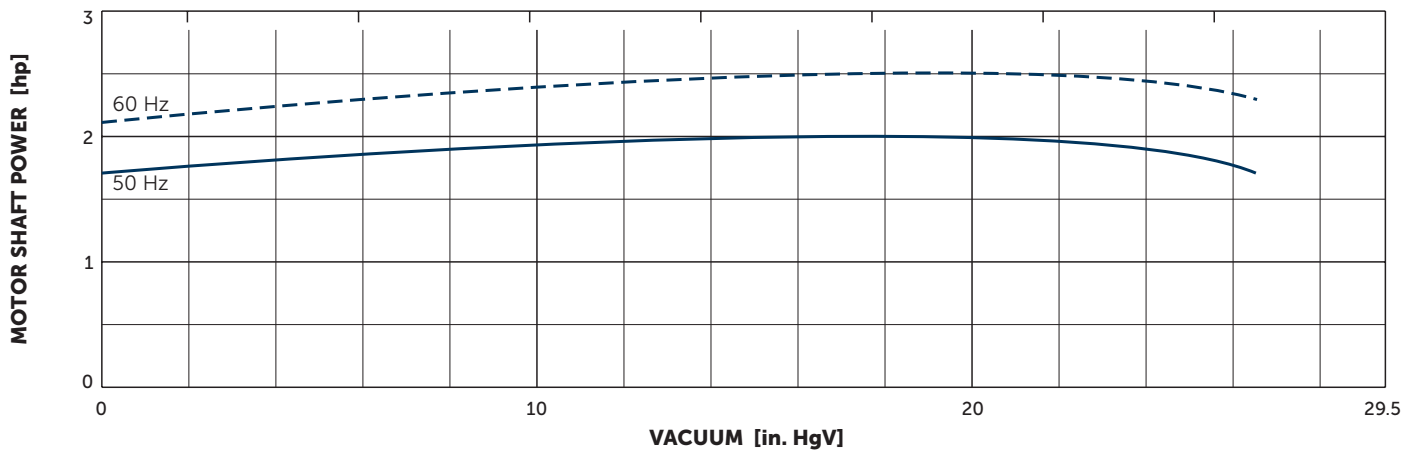
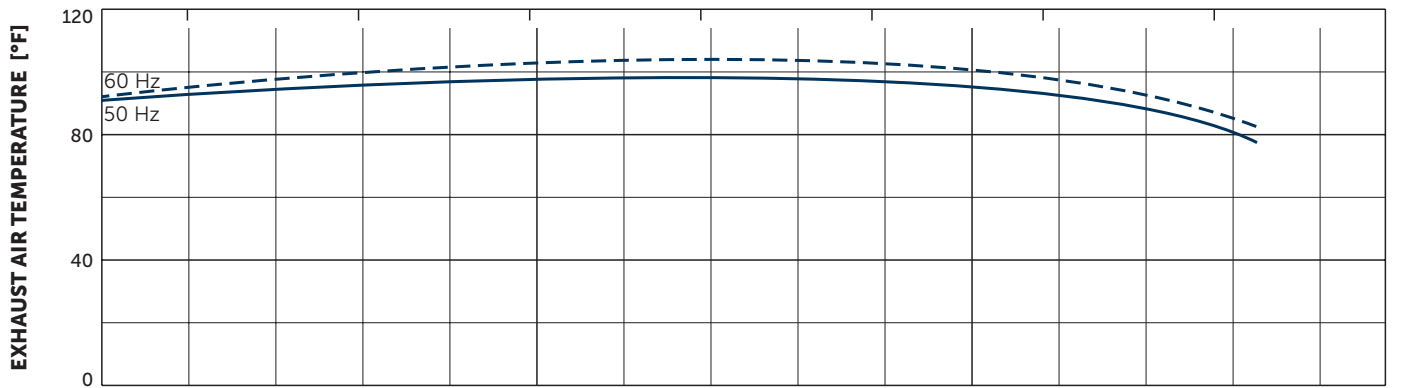
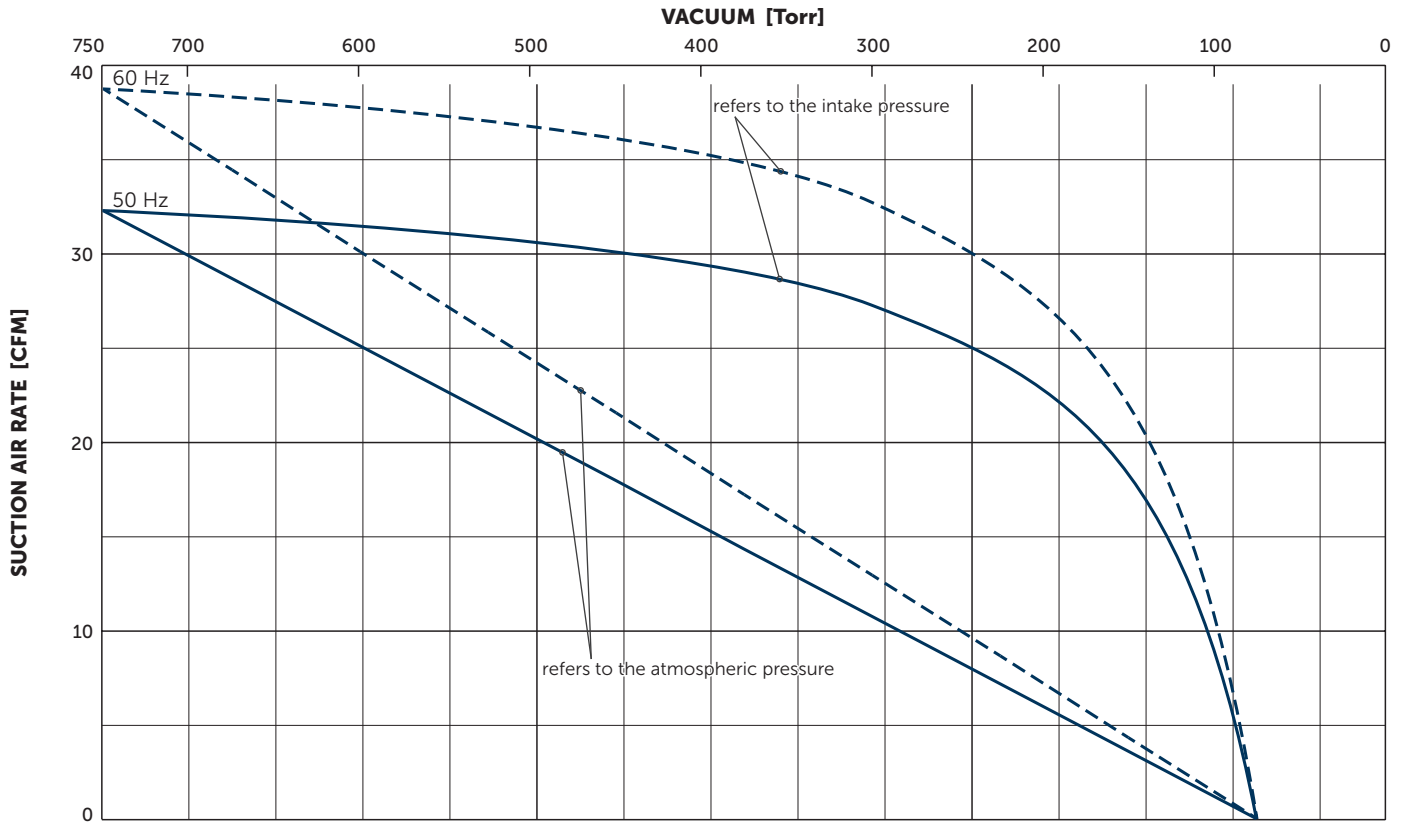

Reference data (atmosphere): 0 in. HgV, 68°F; Tolerance: ±5%

+ VARIANTS AND ACCESSORIES

- **K VX 3.60/0-54** with exhaust connection
- External suction filter¹⁾
- Sound proof box SH 13¹⁾

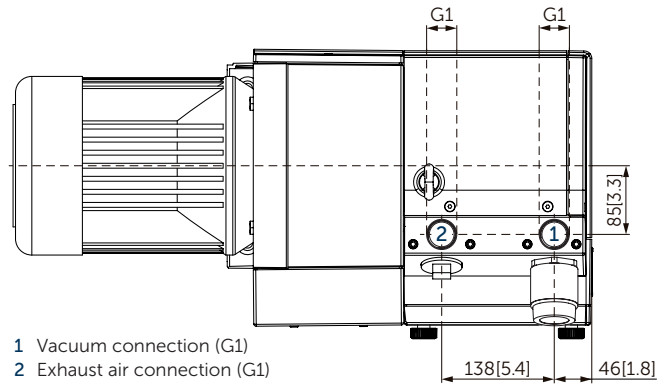

Example for an external suction filter



Sound proof box SH 13

¹⁾ See separate data sheet
• Possible combinations on request

MAKE IT BECKER.

