

DATA SHEET

KVX 3.140

ROTARY VANE VACUUM PUMPS

oil-free

air-cooled

MAKE IT BECKER.



figure KVX 3.80



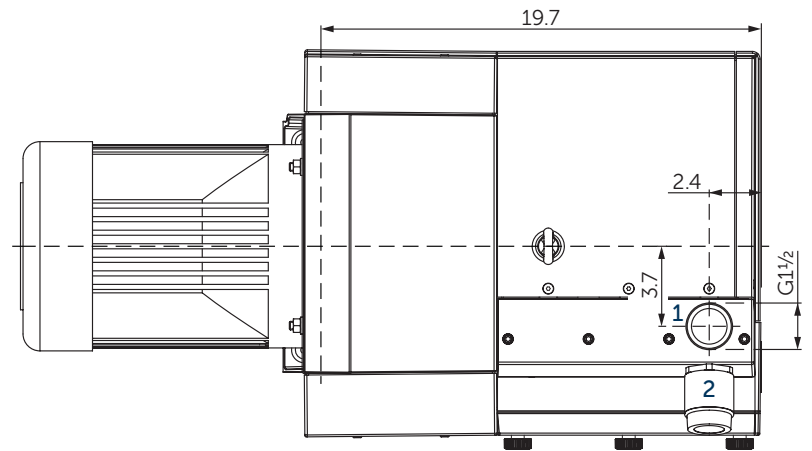
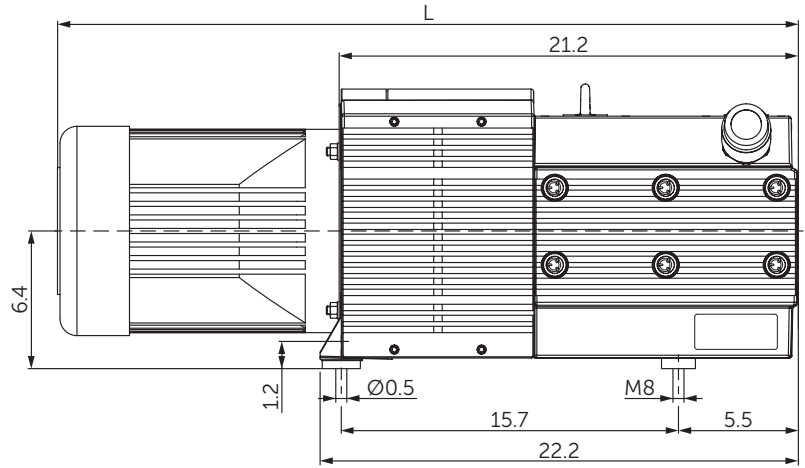
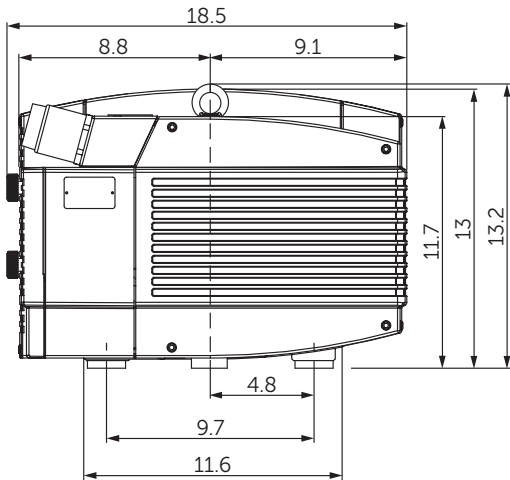

- 1 Vacuum connection (G1¹/₄)
- 2 Vacuum regulating valve
 - Including integrated suction air filter and blow of valve
 - The motor illustration may vary.
 - Dimensions in inch

Suction air rate		Vacuum		Emission sound pressure level ¹⁾		Weight without motor
CFM		in. HgV		dB(A)		lbs
50 Hz	60 Hz	50 Hz	60 Hz	50 Hz	60 Hz	
76	91	26.6	23.6	76	79	172

¹⁾ According to DIN EN ISO 3744 (KpA = 3 dB(A)), 39.4 inch distance, at medium load, both connection sides piped

3~ Motors ¹⁾												L	
#	50 Hz					60 Hz				Version	Weight lbs	inch	
	hp	V	rpm	A	hp	V	rpm	A					
01	5.4	Δ230/Y400	IE3	1445	15.5/8.9	6.4	Δ265/Y460	1745	14.9/8.6	IP55 • ISO F • bimetal	75.0	32.7	
							Δ230/Y400		1720				15.9/9.2
02	5.4	Δ200/Y400	IE3	1465	18.0/9.0	6.0	YY230/Y460	IE3	1759	18.4/9.2	UL(E235514) • CSA CC329B IP55 • ISO F • bimetal	88.2	33.9
							YY208	IE3	1753	18.7			
03						6.4	YY230/Y460	IE3	1781	15.4/8.9	UL(E235514) • CSA CC329B IP55 • ISO F • bimetal	127.9	35.5
							YY208		1770	18.4			
04	5.4	Δ200/Y350	IE3	1467	20.3/11.7	6.0	Δ220/Y380–400	IE3	1760	18.5/10.7–10.2	UL(E235514) • CSA CC329B IP55 • ISO F • bimetal	88.2	33.9
							Δ200/Y350	IE3	1753	19.0/11.0			
05						6.0	Δ400/Y690	IE3	1768	11.0/6.35	UL(E235514) • CSA CC329B IP55 • ISO F • bimetal	88.2	33.9
06						6.4	Δ400/Y690	IE3	1775	10.75/6.2	UL(E365362) • CSA IP55 • ISO F • bimetal	142.2	38.0
07						7.5	YY230/Y460	IE3	1800	18.9/9.45	UL • CSA • NEMA • ISO F	180.0	36.1
							YY208		1750	20.9			

• Current consumption and rotation speed may vary. Tolerance in each case -1.5/+2%

SERIES X: BECKER INNOVATION WITH TOP WARRANTY

Equipped with specially developed vanes, these oil-free rotary vane pumps distinguish themselves by high abrasion resistance, and with that extremely long service lives. Due to the low wear there is also minimal dust, so the series X pumps are perfectly suited for precision processes under clean room conditions.

This innovation branded by Becker is outstanding not only because of its 100 percent oil-free operation, excellent degree of efficiency and low power consumption.

In the area of sensitive vacuum, series X also guarantees precise low-pulsation air conduction.

Becker guarantees for these pumps a vane life-time of 20,000 operating hours or a maximum of 3 years. The enhanced longevity of X series pumps also extends service life intervals, and can cut out the need for frequent service visits with costly pump failures now no longer an issue.



ADVANTAGES

- Quick, clean and quiet
- Oil-free
- Wear resistant
- Energy saving
- Long-life reliability

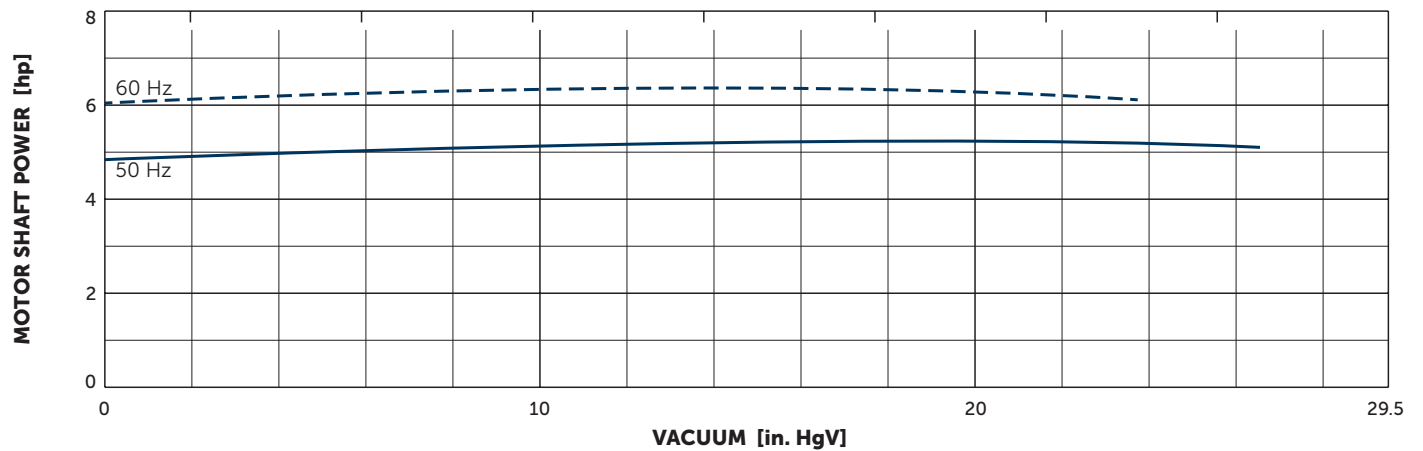
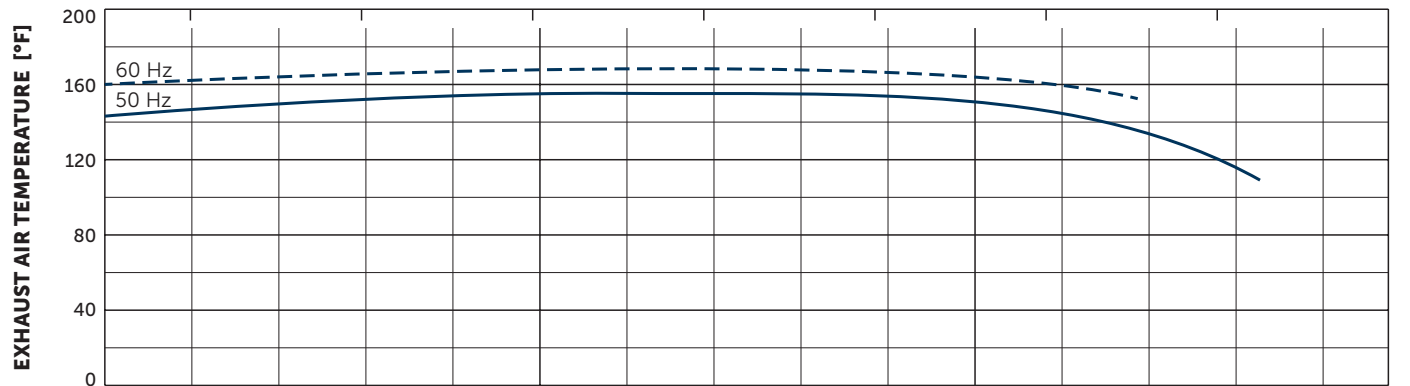
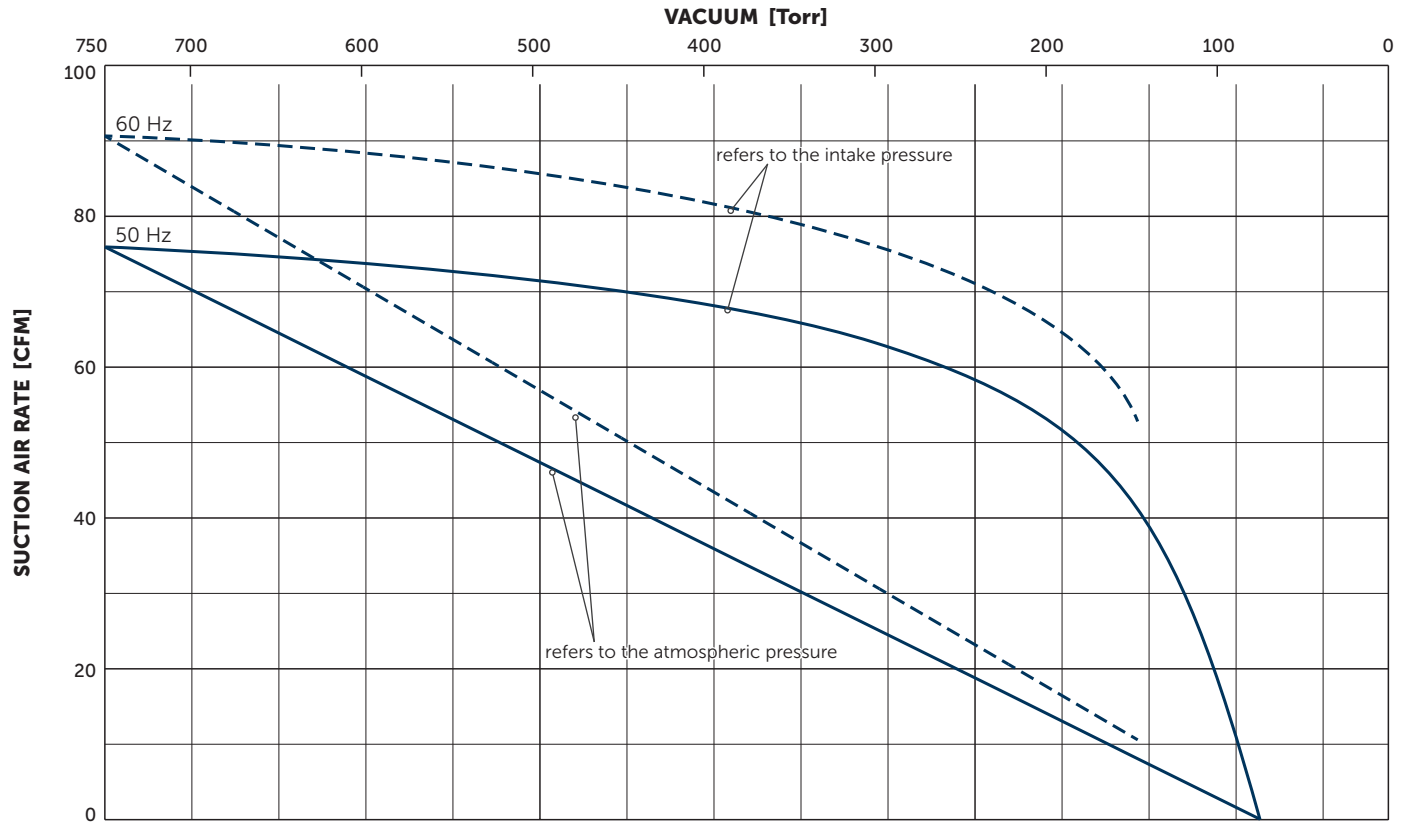

Reference data (atmosphere): 0 in. HgV, 68°F; Tolerance: ±5%

+ VARIANTS AND ACCESSORIES

- **KVX 3.140/0-54** with exhaust connection
- **VARIAIR KVX 3.140/0-400** with frequency inverter¹⁾
- External suction filter¹⁾
- Sound proof box SH 13¹⁾

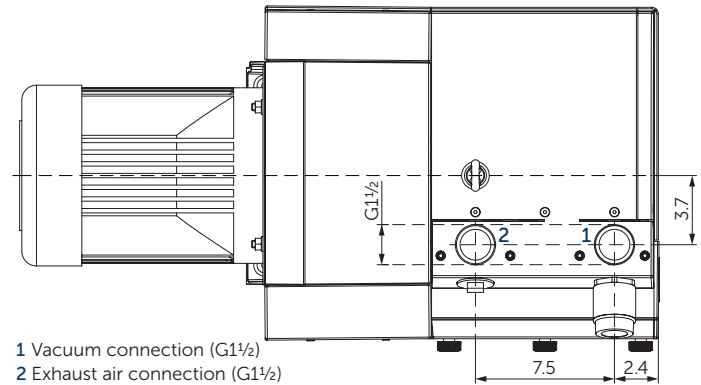

Example for an external suction filter



Sound proof box SH 13

¹⁾ See separate data sheet

- Possible combinations on request



MAKE IT BECKER.