

DATA SHEET

KVT 3.100

ROTARY VANE VACUUM PUMPS

oil-free

air-cooled

MAKE IT BECKER.



3~ Motors ¹⁾												L	
#	50 Hz					60 Hz				Version	Weight lbs	inch	
	hp	V	IE3	rpm	A	hp	V	rpm	A				
01	4.0	Δ230/Y400	IE3	1445	12.1/7.0	4.8	Δ265/Y460	IE3	1735	12.0/6.9	IP55 • ISO F • bimetal	63.9	33.0
							Δ230/Y400		1705	12.7/7.4			
02	4.0	Δ230/Y400	IE3	1460	12.3/7.1	4.8	Δ265/Y460	IE3	1755	12.0/6.9	UL(E365362) • CSA CC334B	81.6	33.5
							Δ230/Y400		1745	12.3/7.1	IP55 • ISO F • bimetal		
03						4.8	YY230/Y460	IE3	1755	12.7/6.3	UL(E365362) • CSA CC334B	81.6	33.5
							YY208		1735	13.5	IP55 • ISO F • bimetal		
04	4.0	Δ200/Y350		1465	14.2/8.2	4.8	Δ220/Y380-400	IE3	1755	13.5/7.8-7.5	UL(E365362) • CSA CC334B	81.6	33.5
							Δ200/Y350		1745	13.8/8.0	IP55 • ISO F • bimetal		
05						4.8	Δ400/Y690	IE3	1760	7.6/4.4	UL(E365362) • CSA CC334B IP55 • ISO F • bimetal	81.6	33.5
06						5.0	YY230/Y460	IE3	1800	12.8/6.4	UL • CSA NEMA	95.0	32.6
							YY208		1730	14.2	ISO F		

• Current consumption and rotation speed may vary. Tolerance in each case -1.5/+2%

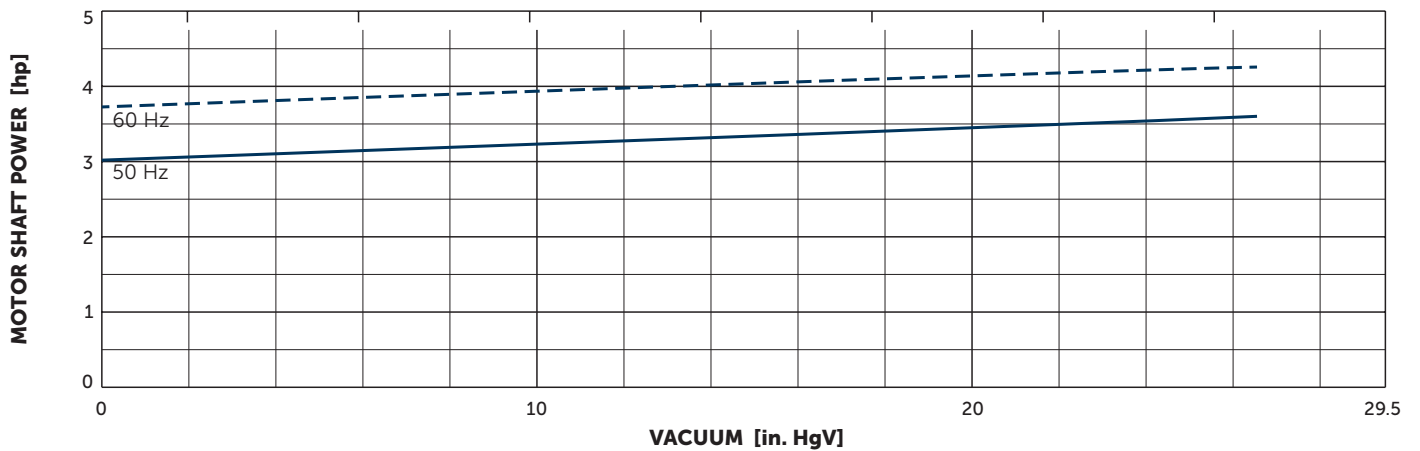
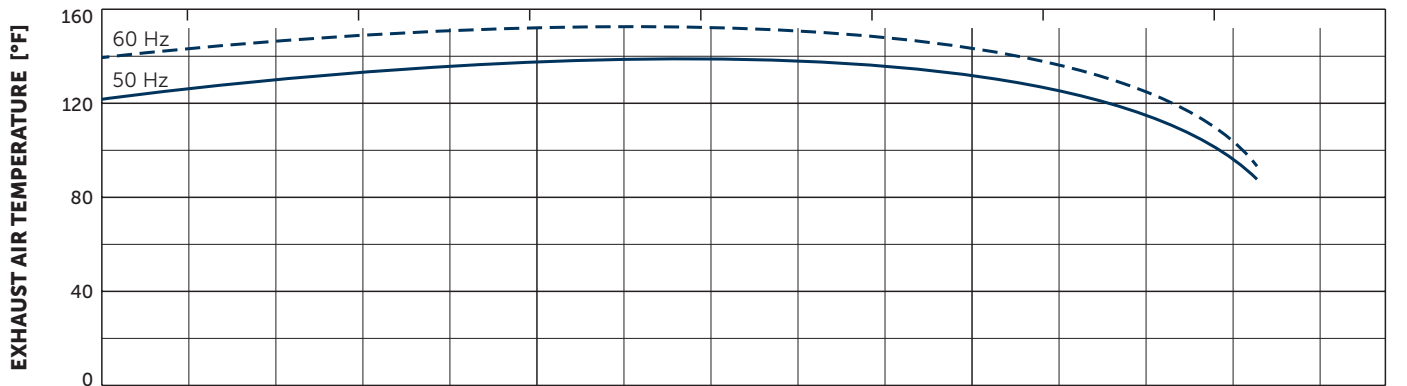
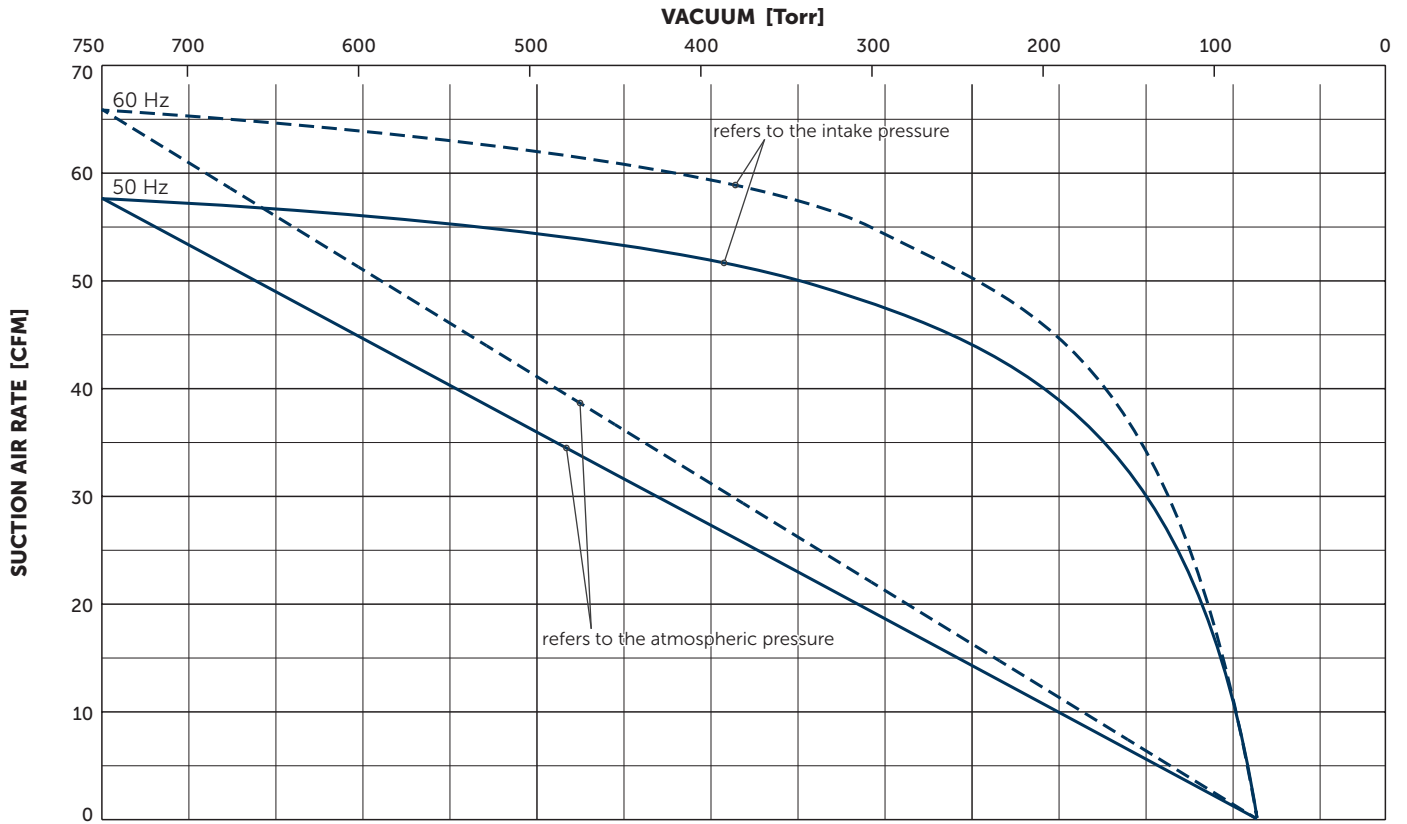

Reference data (atmosphere): 0 in. HgV, 68°F; Tolerance: ±5%

+ VARIANTS AND ACCESSORIES

KVX 3.100

SERIES X: BECKER INNOVATION WITH TOP WARRANTY

Equipped with specially developed vanes, these oil-free rotary vane pumps distinguish themselves by high abrasion resistance, and with that extremely long service lives. Due to the low wear there is also minimal dust, so the series X pumps are perfectly suited for precision processes under clean room conditions.

This innovation branded by Becker is outstanding not only because of its 100 percent oil-free operation, excellent degree of efficiency and low power consumption.

In the area of sensitive vacuum, series X also guarantees precise low-pulsation air conduction.

Becker guarantees for these pumps a vane life-time of 20,000 operating hours or a maximum of 3 years. The enhanced longevity of X series pumps also extends service life intervals, and can cut out the need for frequent service visits with costly pump failures now no longer an issue.



ADVANTAGES

- Quick, clean and quiet
- Oil-free
- Wear resistant
- Energy saving
- Long-life reliability

OTHER VARIANTS AND ACCESSORIES

- **KVT 3.100/0-54** with exhaust connection
- **VARIAIR KVT 3.100/0-400** with frequency inverter¹⁾
- Increased corrosion protection
- External suction filter¹⁾
- Sound proof box SH 13¹⁾

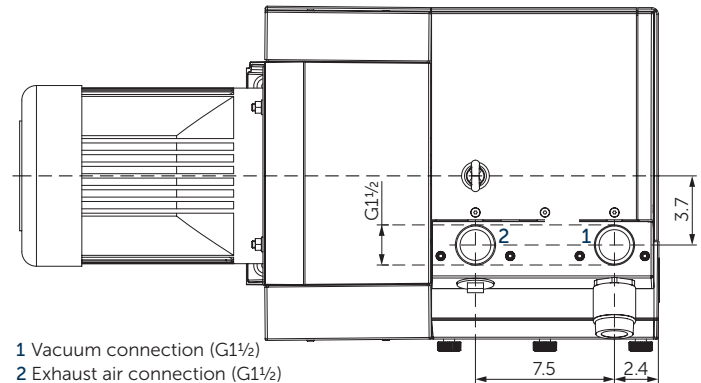

Example for an external suction filter



Sound proof box SH 13

¹⁾ See separate data sheet

- Possible combinations on request

MAKE IT BECKER.

