

REV	DESCRIPTION	ECN #	CHG BY	DATE	APP'D
A	CONVERTED TO 3D		WEB	09/10/19	NAD

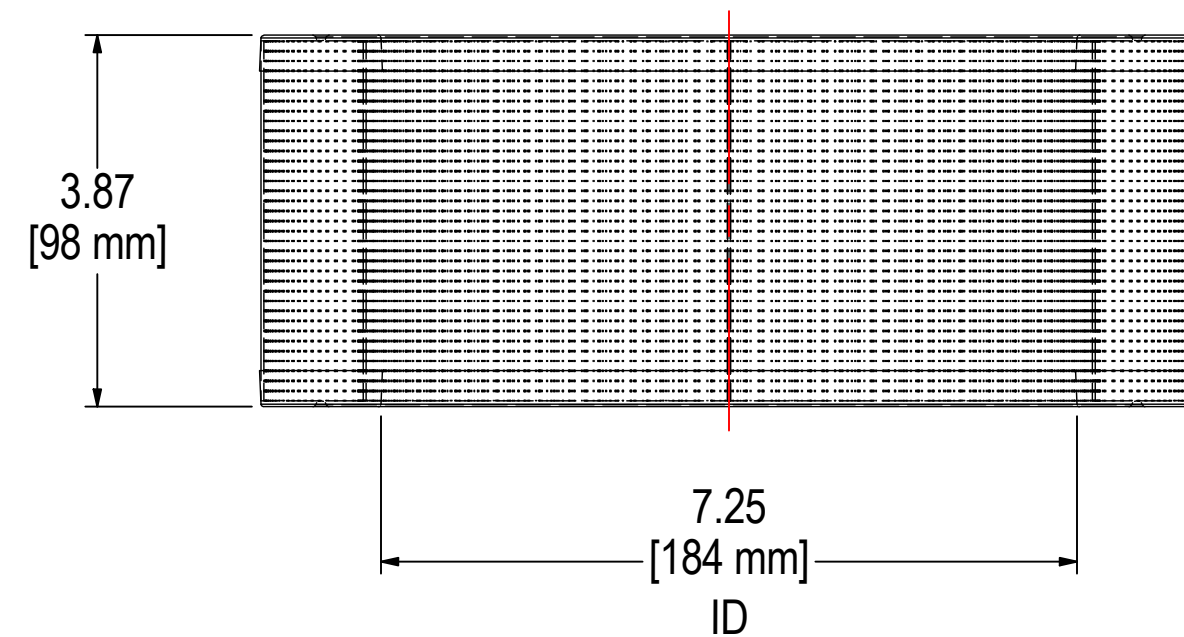
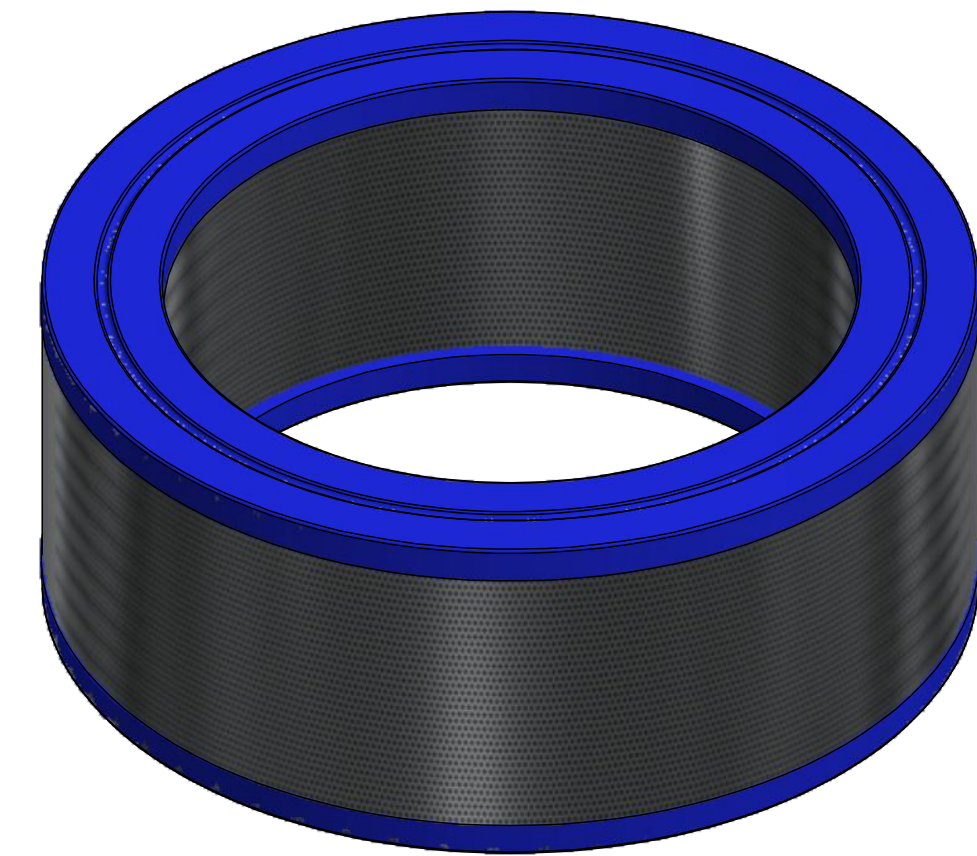
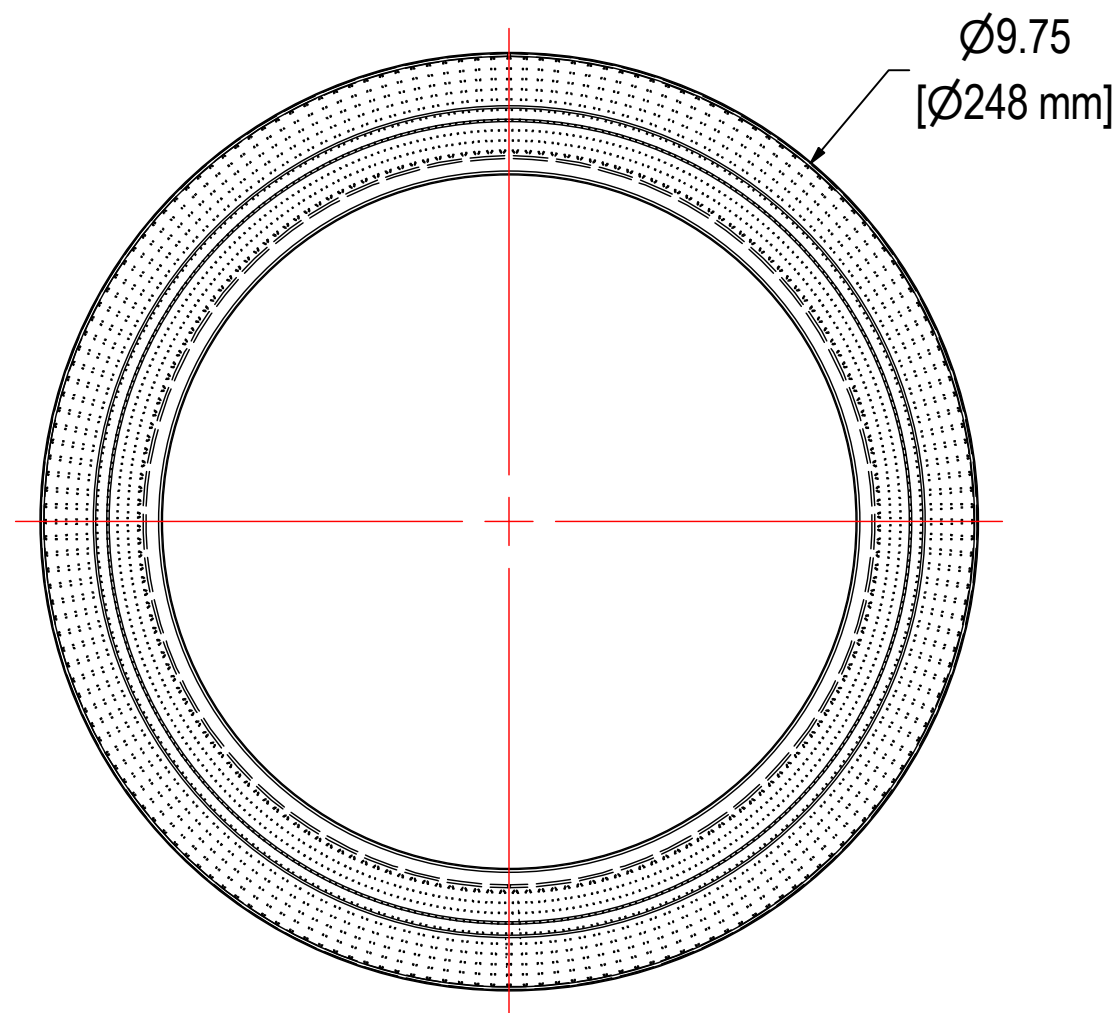

ELEMENT SPECS		
PART NUMBER	32-04	
MATERIAL	PAPER	
FLOW RATE	350 CFM	595 m <sup>3</sup> /hr
SURFACE AREA	7.8 ft <sup>2</sup>	0.7 m <sup>2</sup>
I.D.	7.25"	184mm
O.D.	9.75"	248mm
HEIGHT	3.87"	98mm

THE INFORMATION CONTAINED HEREIN IS CONFIDENTIAL AND THE PROPERTY OF SOLBERG MANUFACTURING INC. AND IT IS FURNISHED TO YOU WITH THE EXPRESS UNDERSTANDING THAT IT WILL NOT BE REPRODUCED, COPIED IN ANY MANNER, LOANED OR OTHERWISE TRANSFERRED TO OTHERS ENTIRELY OR IN PART, NOR USED FOR ANY PURPOSE OTHER THAN FOR WHICH IT WAS FURNISHED. IT WILL BE RETURNED UPON REQUEST TO SOLBERG MANUFACTURING INC. THE ABOVE RESTRICTION IS IN ADDITION TO, AND DOES NOT IN ANY WAY ALTER, ANY OTHER RESTRICTIONS WHICH MAY APPLY TO THE INFORMATION CONTAINED HEREIN.

**TOLERANCES**  
 DIMENSIONS ARE FOR REFERENCE ONLY. ALL DIMENSIONS ARE SUBJECT TO CHANGE UPON PRODUCTION.  
 UNLESS OTHERWISE SPECIFIED:  
 -DIMENSIONS ARE IN INCHES  
 -REF: APPROXIMATE DIMENSIONS, NO TOLERANCES APPLY  
 -FINISH: BREAK EDGES TO .005-.020 RADIUS/CHAMFER

MODEL NUMBER: 32-04

DESCRIPTION: 32-04, PAPER

PROJECT: SD12550

DRAWN BY: CRW  
 DATE: 12/14/2006

APPROVED BY: MJC  
 DATE: 12/14/2006

SHEET: 1 OF 1

REV: A



**SOLBERG**<sup>®</sup>  
 Filtration • Separation • Silencing  
 630.773.1363 • www.solbergmfg.com